

2004 Isuzu Ascender LS

2004 BRAKES Park Brake - Ascender

2004 BRAKES

Park Brake - Ascender

SPECIFICATIONS

FASTENER TIGHTENING SPECIFICATIONS

Fastener Tightening Specifications

Application	Specification	
	Metric	English
Park Brake Backing Plate Attaching Bolts	135 N.m	100 lb ft
Park Brake Cable Attaching Nuts	17 N.m	13 lb ft
Park Brake Cable Retaining Bracket Bolt	10 N.m	7 lb ft
Park Brake Lamp Switch Retaining Bolt	4 N.m	35 lb in
Park Brake Lever Mounting Nuts	25 N.m	18 lb ft
Park Brake Cable Mounting Bracket Bolts	17 N.m	13 lb ft

DIAGNOSTIC INFORMATION AND PROCEDURES

DIAGNOSTIC STARTING POINT - PARK BRAKE

Begin the system diagnosis by reviewing the system description and operation. Reviewing the description and operation information will help you determine the correct symptom diagnostic procedure when a malfunction exists. Reviewing the description and operation information will also help you determine if the condition described by the customer is normal operation. Refer to **Symptoms - Park Brake** in order to identify the correct procedure for diagnosing the system and where the procedure is located.

SYMPTOMS - PARK BRAKE

IMPORTANT: Review the system operation in order to familiarize yourself with the system functions.

Refer to **Park Brake System Description and Operation**.

Visual/Physical Inspection

- Inspect for aftermarket devices which could affect the operation of the park brake system.
- Inspect the easily accessible or visible system components for obvious damage or conditions which could cause the symptom.

Symptom List

Refer to a symptom diagnostic procedure from the following list in order to diagnose the symptom:

2004 Isuzu Ascender LS

2004 BRAKES Park Brake - Ascender

Park Brake Will Not Hold or Release

PARK BRAKE WILL NOT HOLD OR RELEASE

Park Brake Will Not Hold or Release

Step	Action	Yes	No
1	Were you sent here from the Park Brake Symptom table?	Go to Step 2	Go to <u>Diagnostic Starting Point - Park Brake</u>
2	Inspect the park brake system for proper operation. Refer to <u>Park Brake System Diagnosis</u> . Did you find and correct a condition?	Go to Step 5	Go to Step 3
3	Inspect the disc brake system for proper operation. Refer to <u>Disc Brake System Diagnosis</u> in Hydraulic Brakes. Did you find and correct a condition?	Go to Step 5	Go to Step 4
4	Inspect the hydraulic brake system for proper operation. Refer to <u>Hydraulic Brake System Diagnosis</u> in Hydraulic Brakes. Did you find and correct a condition?	Go to Step 5	Go to <u>Diagnostic Starting Point - Park Brake</u>
5	Road test the vehicle in order to confirm proper operation. Refer to <u>Brake System Vehicle Road Test</u> in Hydraulic Brakes. Is the condition still present?	Go to Step 2	System OK

PARK BRAKE SYSTEM DIAGNOSIS

Park Brake System Diagnosis

Step	Action	Yes	No
DEFINITION: This diagnostic table is designed to diagnose ONLY the components of the PARK brake system in order to determine if the PARK brake system is operating properly. You will be directed by the appropriate Symptom Table to go to other brake system diagnostic tables as appropriate.			
1	Were you sent here from a Hydraulic Brake Symptom Table?	Go to Step 4	Go to Step 2
2	Were you sent here from a Park Brake Symptom Table?	Go to Step 4	Go to Step 3
3	Is the symptom related to the ability of the park brake system to hold and/or release?	Go to <u>Diagnostic Starting Point - Park Brake</u>	Go to <u>Diagnostic Starting Point - Hydraulic Brakes</u> in Hydraulic Brakes
4	<ol style="list-style-type: none"> 1. Raise and support the vehicle with the rear axle supported by jack stands. Refer to <u>Lifting and Jacking the Vehicle</u> in General Information. 2. Shift the transmission into NEUTRAL. 		

2004 Isuzu Ascender LS

2004 BRAKES Park Brake - Ascender

	<p>3. With the park brake RELEASED, attempt to rotate the rear wheels to check the rear brakes for a significant amount of drag.</p> <p>Do the rear brakes have a significant amount of drag?</p>	Go to Step 11	Go to Step 5
5	<p>1. Shift the transmission into NEUTRAL.</p> <p>2. Apply the park brake.</p> <p>3. Attempt to rotate the rear wheels to check the rear brakes for a significant amount of drag.</p> <p>Do the rear brakes have a significant amount of drag?</p>	Go to Step 6	Go to Step 7
6	<p>1. Release the park brake.</p> <p>2. Rotate the rear wheels to check the rear brakes for a significant reduction in the amount of drag.</p> <p>Did the rear brakes exhibit a significant reduction in the amount of drag?</p>	Go to Step 20	Go to Step 11
7	<p>Visually check the park brake cable connections and the cables that are accessible on the UNDERSIDE of the vehicle for disconnections and/or damage. Were any or the park brake cables disconnected and/or damaged?</p>	Go to Step 8	Go to Step 9
8	<p>Reconnect or replace the park brake cables as necessary. Refer to <u>Park Brake Cable Replacement</u>. Did you complete the repair and/or replacement?</p>	Go to Step 9	-
9	<p>Check the adjustment of the park brake. Refer to <u>Park Brake Adjustment</u>. Was the park brake adjusted properly?</p>	Go to Step 11	Go to Step 10
10	<p>Adjust the park brake. Refer to <u>Park Brake Adjustment</u>. Were you able to attain adjustment of the park brake?</p>	Go to Step 16	Go to Step 11
11	<p>NOTE: Do not depress the brake pedal with the brake rotors and/or the brake drums removed, or with the brake calipers repositioned away from the brake rotors, or damage to the brake system may result.</p> <p>1. Remove the rear brake rotors. Refer to <u>Brake Rotor Replacement - Rear</u> in Disc Brakes.</p> <p>2. Inspect the park brake shoe hardware for looseness, damaged, broken or missing components.</p> <p>3. Check the park brake actuators for a seized condition.</p>		

2004 Isuzu Ascender LS

2004 BRAKES Park Brake - Ascender

	Does the park brake hardware and/or the park brake actuators require replacement?	Go to Step 12	Go to Step 13
12	<ol style="list-style-type: none"> 1. Replace park brake hardware components as necessary. Refer to <u>Park Brake Shoe Replacement</u>. 2. Replace the park brake actuators as necessary. Refer to <u>Park Brake Actuator Replacement</u>. <p>Did you complete the replacement?</p>	Go to Step 13	-
13	<p>Have an assistant apply and release the park brake, while you observe the park brake cables for free movement.</p> <p>Did the park brake cables move freely?</p>	Go to Step 14	Go to Step 17
14	<p>Check the adjustment of the park brake. Refer to <u>Park Brake Adjustment</u>.</p> <p>Was the park brake adjusted properly?</p>	Go to Step 16	Go to Step 15
15	<p>Adjust the park brake. Refer to <u>Park Brake Adjustment</u>.</p> <p>Were you able to attain adjustment of the park brake?</p>	Go to Step 16	Go to Step 25
16	<ol style="list-style-type: none"> 1. With the transmission still in NEUTRAL, apply the park brake. 2. Attempt to rotate the rear wheels to check the rear brakes for a significant amount of drag. 3. Release the park brake. 4. Rotate the rear wheels to check the rear brakes for a significant reduction of drag. <p>Did the park brake apply and release properly?</p>	Go to Step 27	Return to Symptom Table
17	<p>Disconnect the park brake cable connections that are accessible on the UNDERSIDE of the vehicle one at a time and check each cable for free movement.</p> <p>Do any of the park brake cables accessible on the underside of the vehicle require replacement?</p>	Go to Step 18	Go to Step 19
18	<p>Replace any of the park brake cables that do not have free movement (not releasing properly). Refer to <u>Park Brake Cable Replacement</u>.</p> <p>Did you complete the replacement?</p>	Go to Step 23	-
19	<p>Replace the park brake pedal assembly (not releasing properly). Refer to <u>Park Brake Lever Assembly Replacement</u>.</p> <p>Did you complete the replacement?</p>	Go to Step 24	-
20	<p>Check the adjustment of the park brake. Refer to <u>Park Brake Adjustment</u>.</p>		

2004 Isuzu Ascender LS

2004 BRAKES Park Brake - Ascender

	Is the park brake adjusted properly?	Go to Step 27	Go to Step 21
21	Adjust the park brake. Refer to <u>Park Brake Adjustment</u> . Were you able to attain adjustment of the park brake system?	Go to Step 26	Go to Step 22
22	<ol style="list-style-type: none"> 1. Remove the rear brake rotors, if they have not yet been removed. Refer to <u>Brake Rotor Replacement - Rear</u> in Disc Brakes. 2. Check the park brake actuators for a seized condition. 3. Replace the park brake actuators as necessary. Refer to <u>Park Brake Actuator Replacement</u>. <p>Did you find and correct a condition?</p>	Go to Step 23	Go to Step 25
23	Adjust the park brake. Refer to <u>Park Brake Adjustment</u> . Were you able to attain adjustment of the park brake system?	Go to Step 26	Go to Step 25
24	Adjust the park brake. Refer to <u>Park Brake Adjustment</u> . Were you able to attain adjustment of the park brake system?	Go to Step 26	Return to Symptom Table
25	<ol style="list-style-type: none"> 1. Replace the component that is used to adjust the park brake system. Refer to <u>Park Brake Lever Assembly Replacement</u>. 2. Adjust the park brake. Refer to <u>Park Brake Adjustment</u>. <p>Did you complete the replacement and adjustment?</p>	Go to Step 26	Return to Symptom Table
26	<ol style="list-style-type: none"> 1. With the transmission still in NEUTRAL, apply the park brake. 2. Attempt to rotate the rear wheels to check the rear brakes for a significant amount of drag. 3. Release the park brake. 4. Rotate the rear wheels to check the rear brakes for a significant reduction of drag. <p>Did the park brake apply and release properly?</p>	Go to Step 27	Return to Symptom Table
27	Install or connect any components that were removed or disconnected during diagnosis. Did you complete the operation?	Park Brake System OK Return to Symptom Table	-

PARK BRAKE SHOE INSPECTION

CAUTION: Refer to Brake Dust Caution in Cautions and Notices.

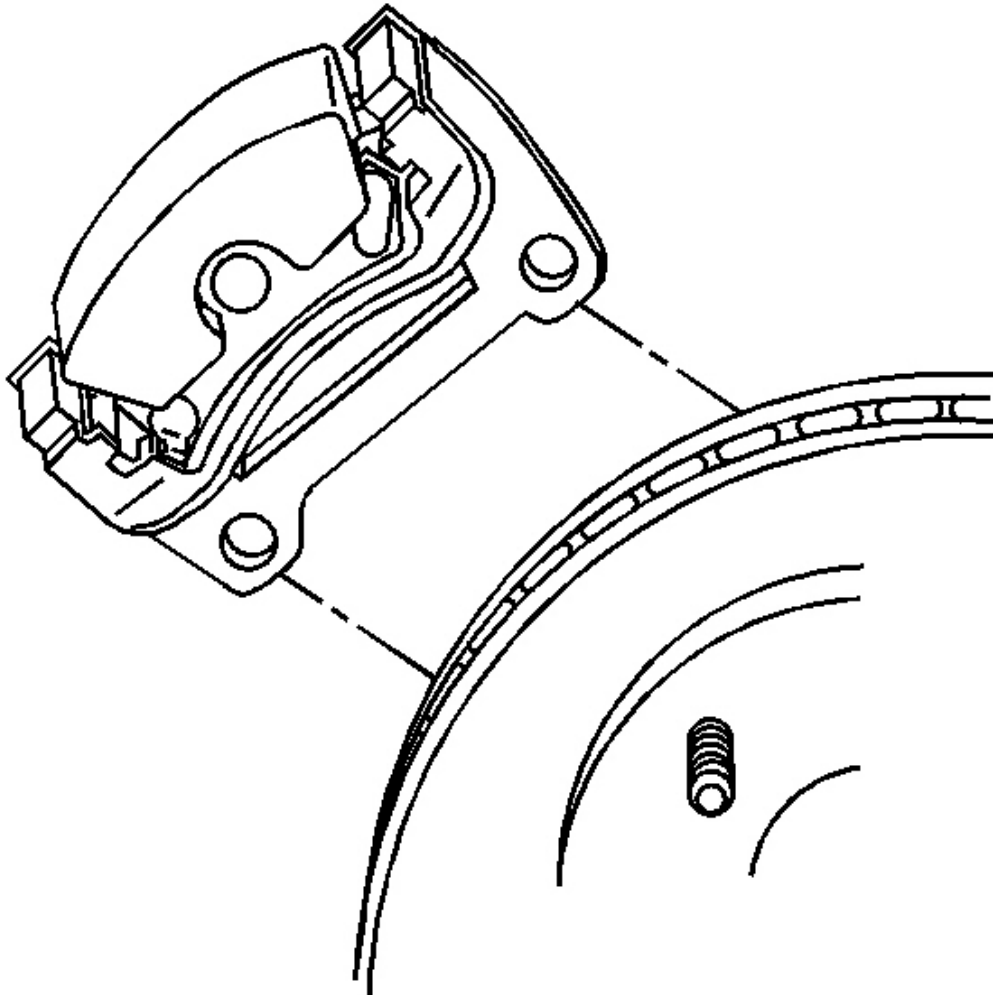

Fig. 1: View Of Caliper Bracket
Courtesy of GENERAL MOTORS CORP.

1. Raise the vehicle. Refer to Lifting and Jacking the Vehicle in General Information.
2. Remove the tire and wheel. Refer to Tire and Wheel Removal and Installation in Suspension.

3. Remove the rear brake caliper and bracket. Refer to **Brake Caliper Bracket Replacement - Rear** in Disc Brakes.

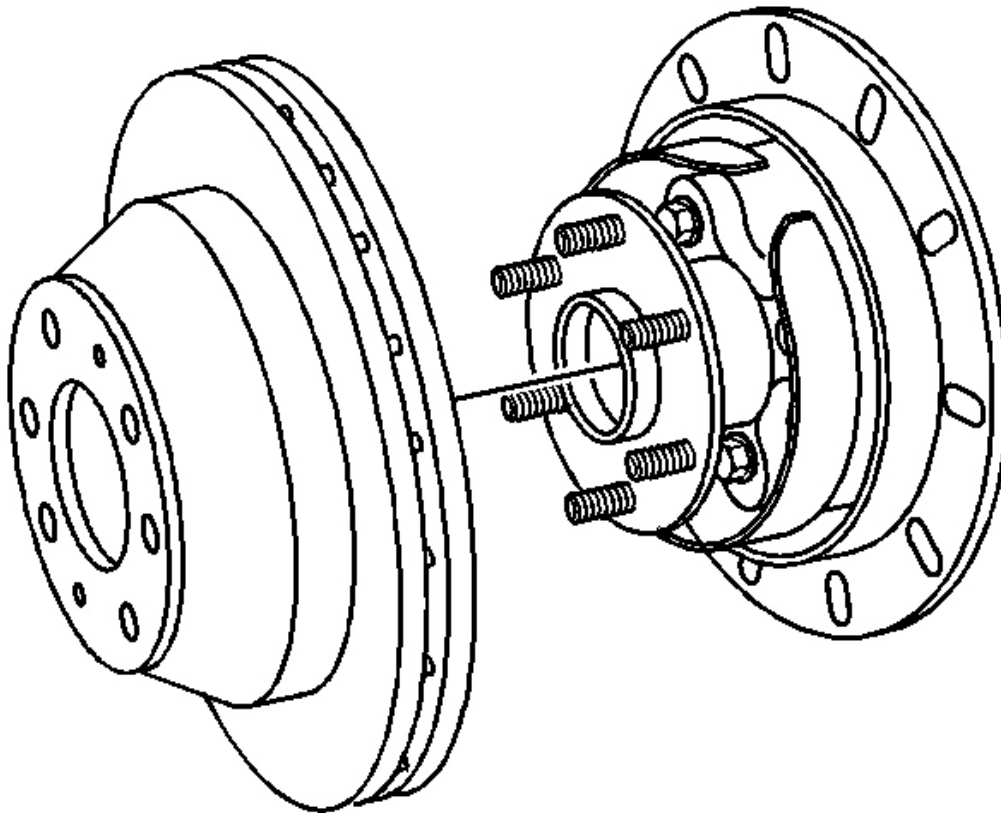

Fig. 2: View Of Rotor To Hub
Courtesy of GENERAL MOTORS CORP.

4. Remove the rear brake rotor.
5. Inspect the park brake shoe and lining and replace if any of the following conditions are found:
 - Excessive wear indicated by the park brake lining being worn down to the shoe
 - Brake lining cracking
 - Oil or fluid contamination of the brake lining

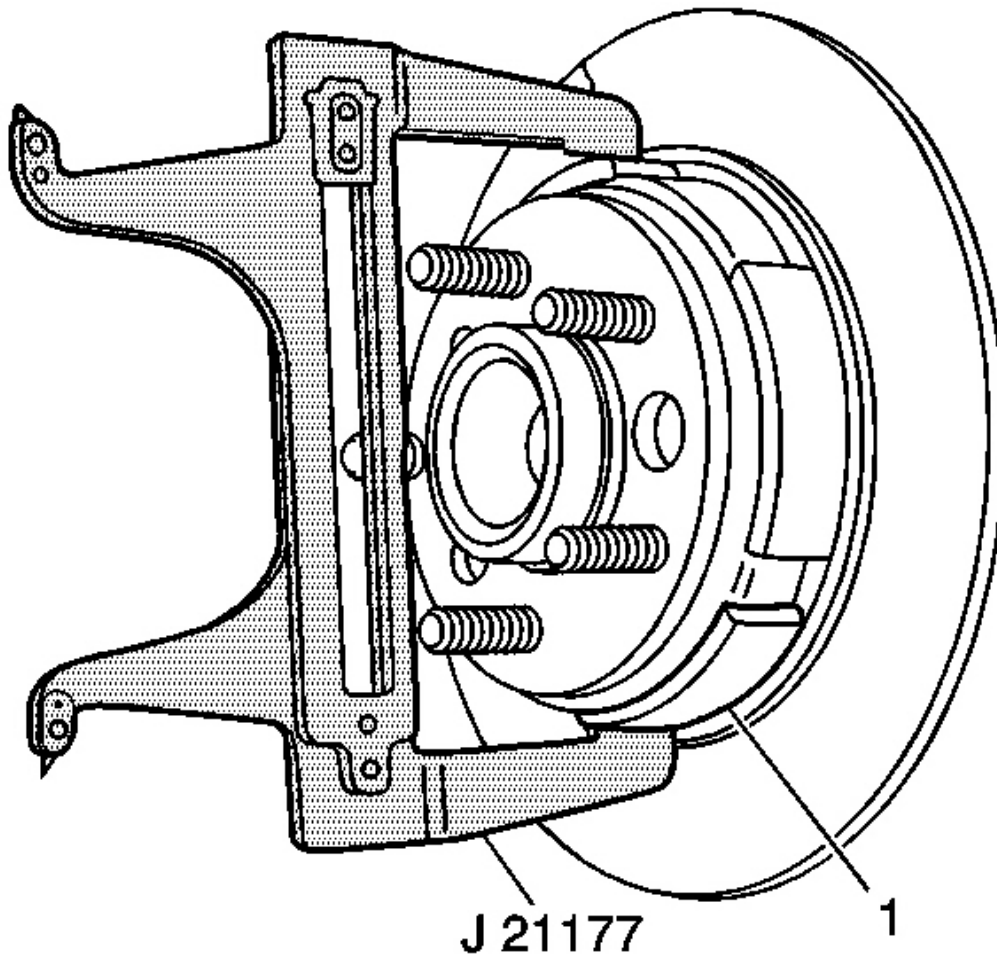

Fig. 3: Adjusting Parking Brake Shoes Using Special Tool
Courtesy of GENERAL MOTORS CORP.

6. Adjust the park brake shoe. Refer to **Park Brake Adjustment**.

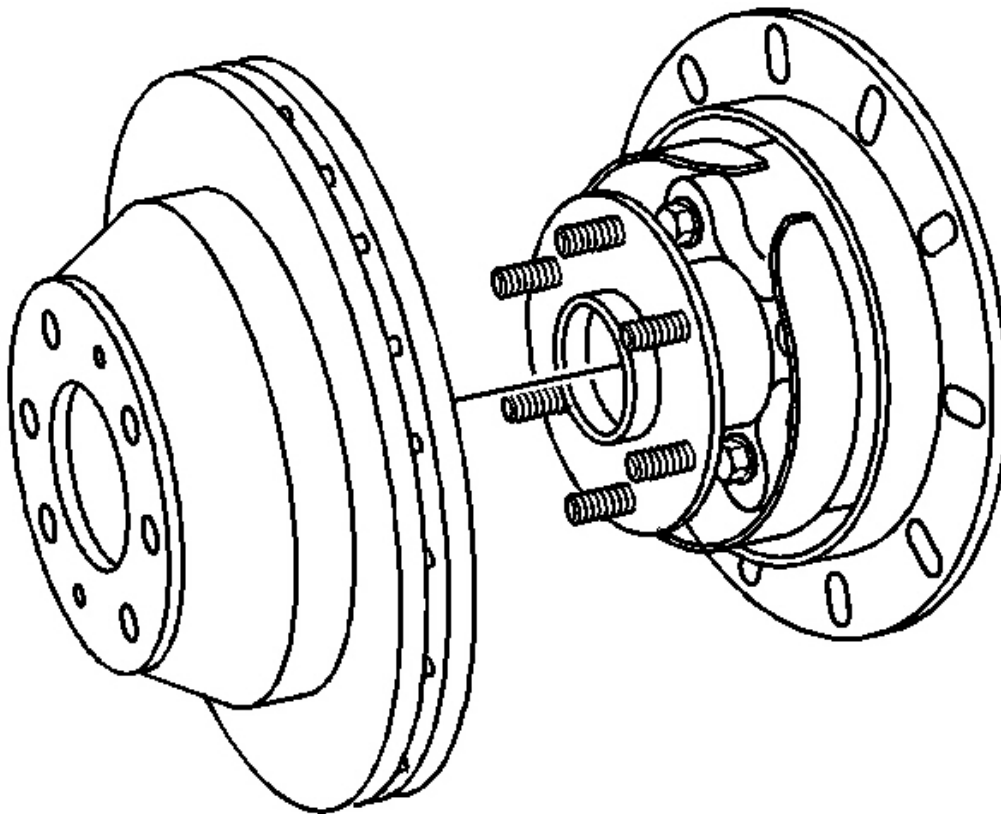

Fig. 4: View Of Rotor To Hub
Courtesy of GENERAL MOTORS CORP.

7. Install the rear brake rotor.

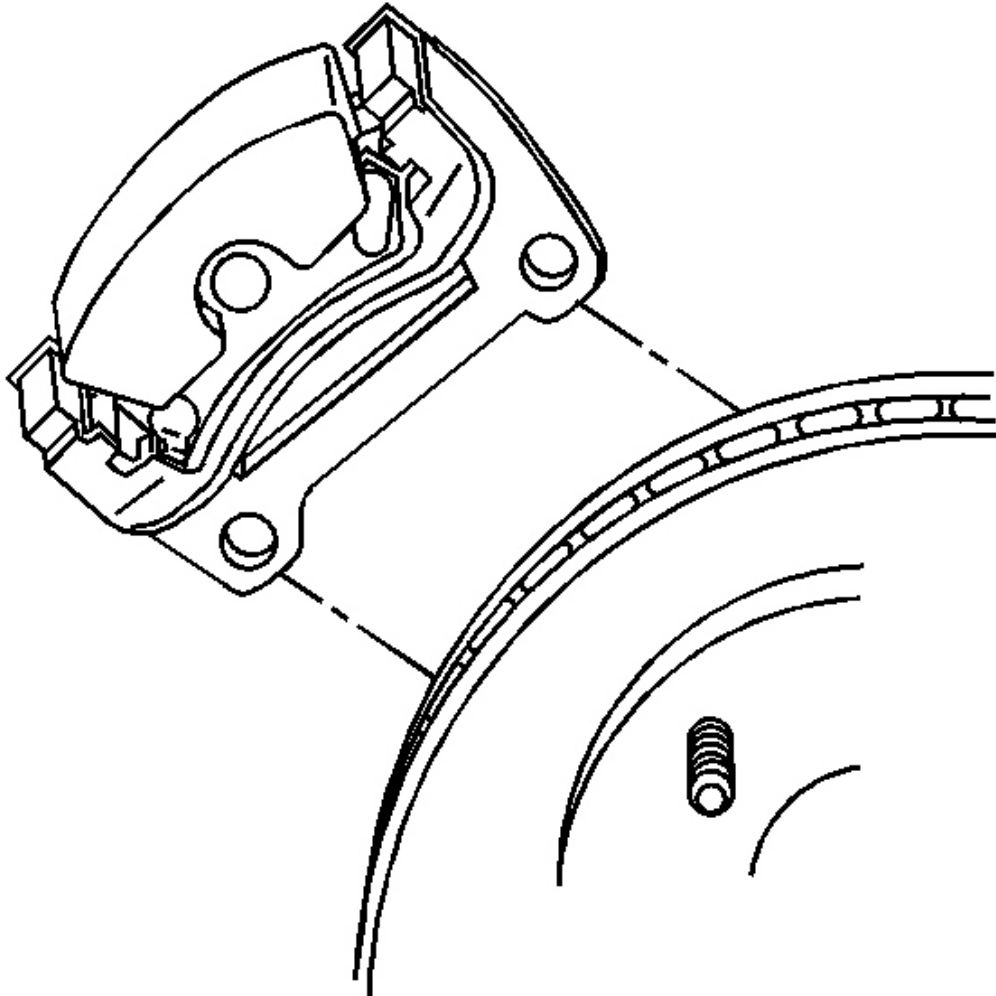

Fig. 5: View Of Caliper Bracket
Courtesy of GENERAL MOTORS CORP.

8. Install the rear brake caliper and bracket. Refer to **Brake Caliper Bracket Replacement - Rear** in Disc Brakes.
9. Install the tire and wheel. Refer to **Tire and Wheel Removal and Installation** in Suspension.
10. Lower the vehicle. Refer to **Lifting and Jacking the Vehicle** in General Information.

REPAIR INSTRUCTIONS

PARK BRAKE SHOE REPLACEMENT

CAUTION: Refer to Brake Dust Caution in Cautions and Notices.

Removal Procedure

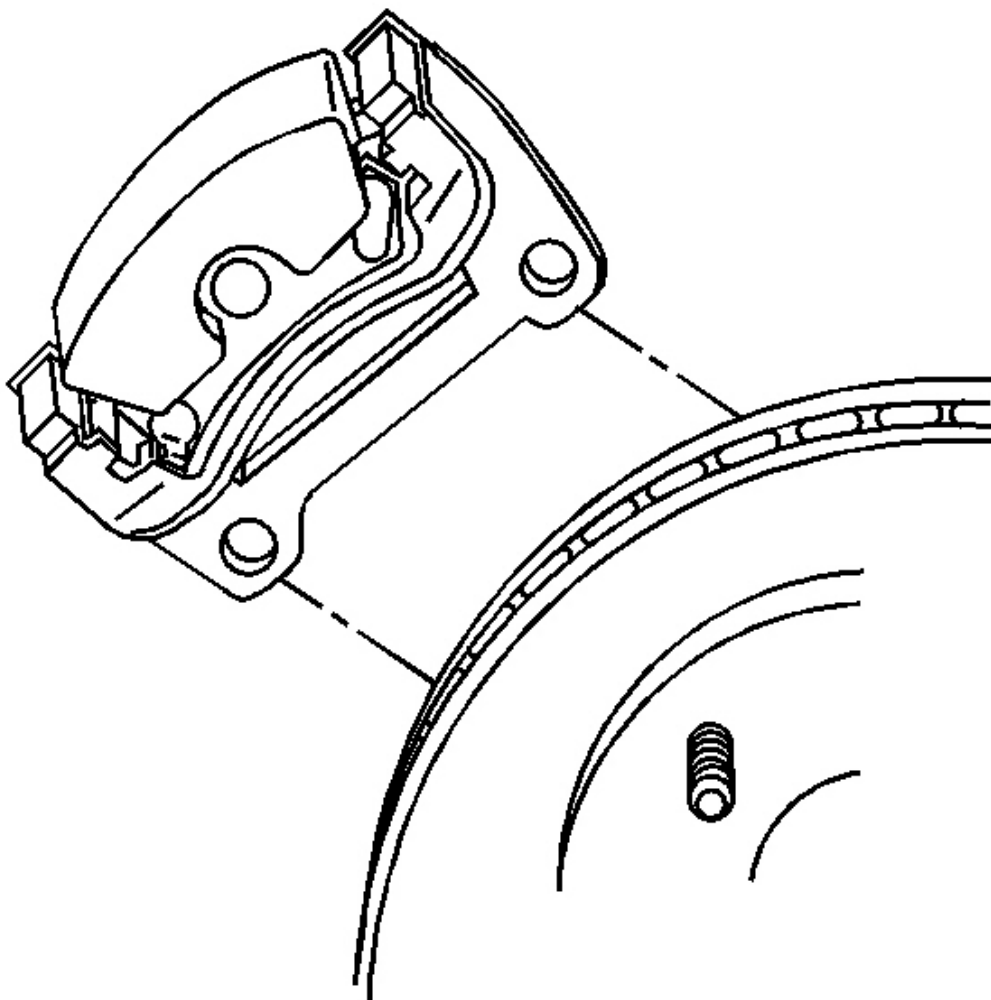

Fig. 6: View Of Caliper Bracket
Courtesy of GENERAL MOTORS CORP.

1. Release the park brake, if applied.
2. Raise and the vehicle. Refer to Lifting and Jacking the Vehicle in General Information.

3. Remove the wheel and the tire. Refer to Tire and Wheel Removal and Installation in Suspension.

IMPORTANT: In the following service procedure, the brake caliper and mounting bracket does not have to be separated. Relocated the brake caliper and bracket to the side and secure.

4. Remove the brake caliper and bracket. Refer to Brake Caliper Bracket Replacement - Rear .

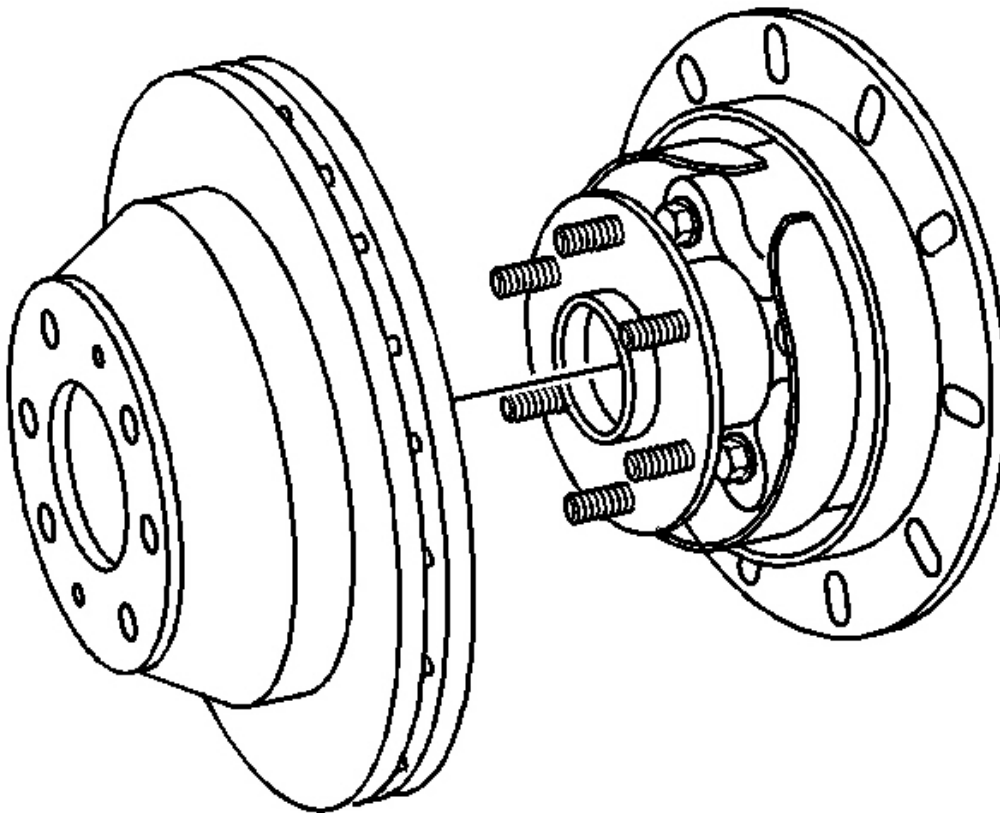

Fig. 7: View Of Rotor To Hub
Courtesy of GENERAL MOTORS CORP.

5. Remove the brake rotor.

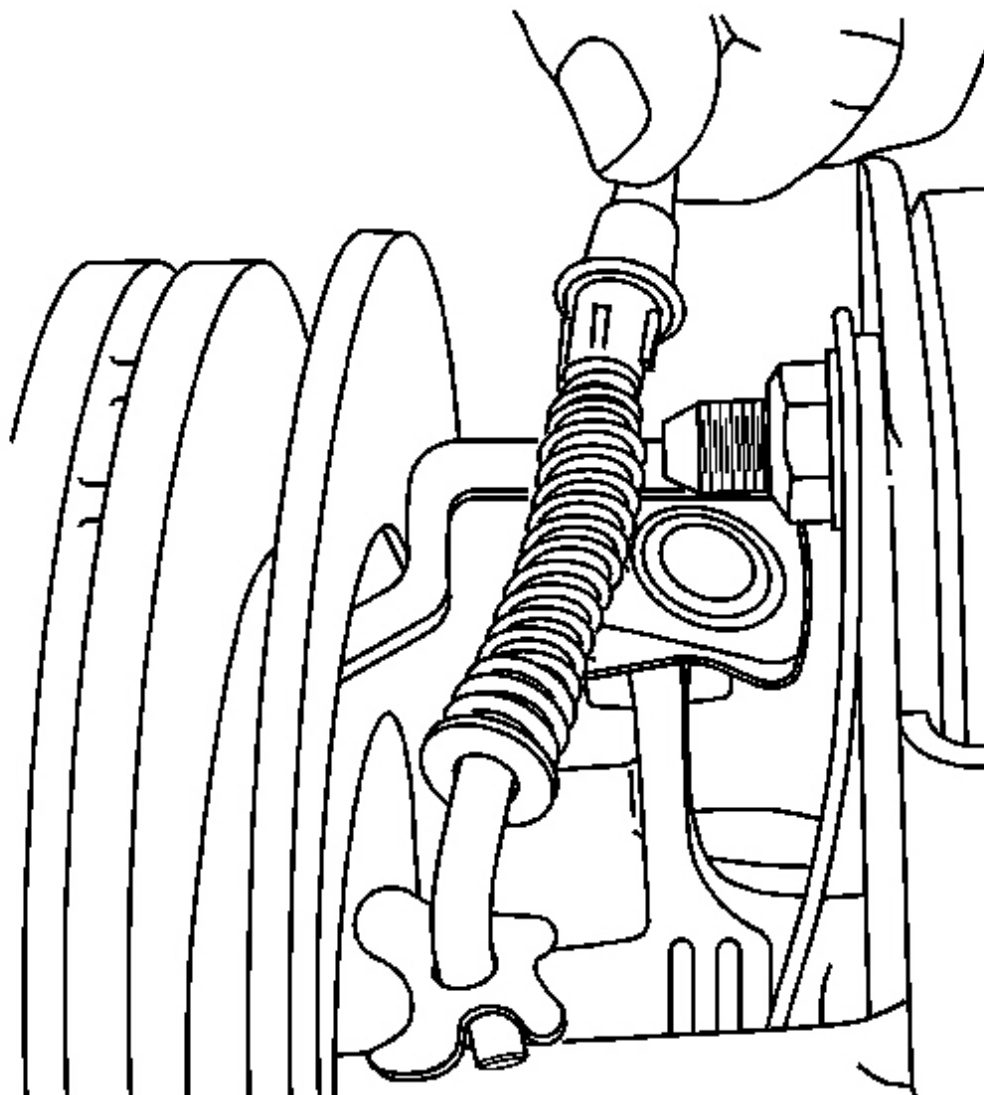

Fig. 8: View Of Parking Brake Cable
Courtesy of GENERAL MOTORS CORP.

6. Remove the park brake cable from the park brake lever.

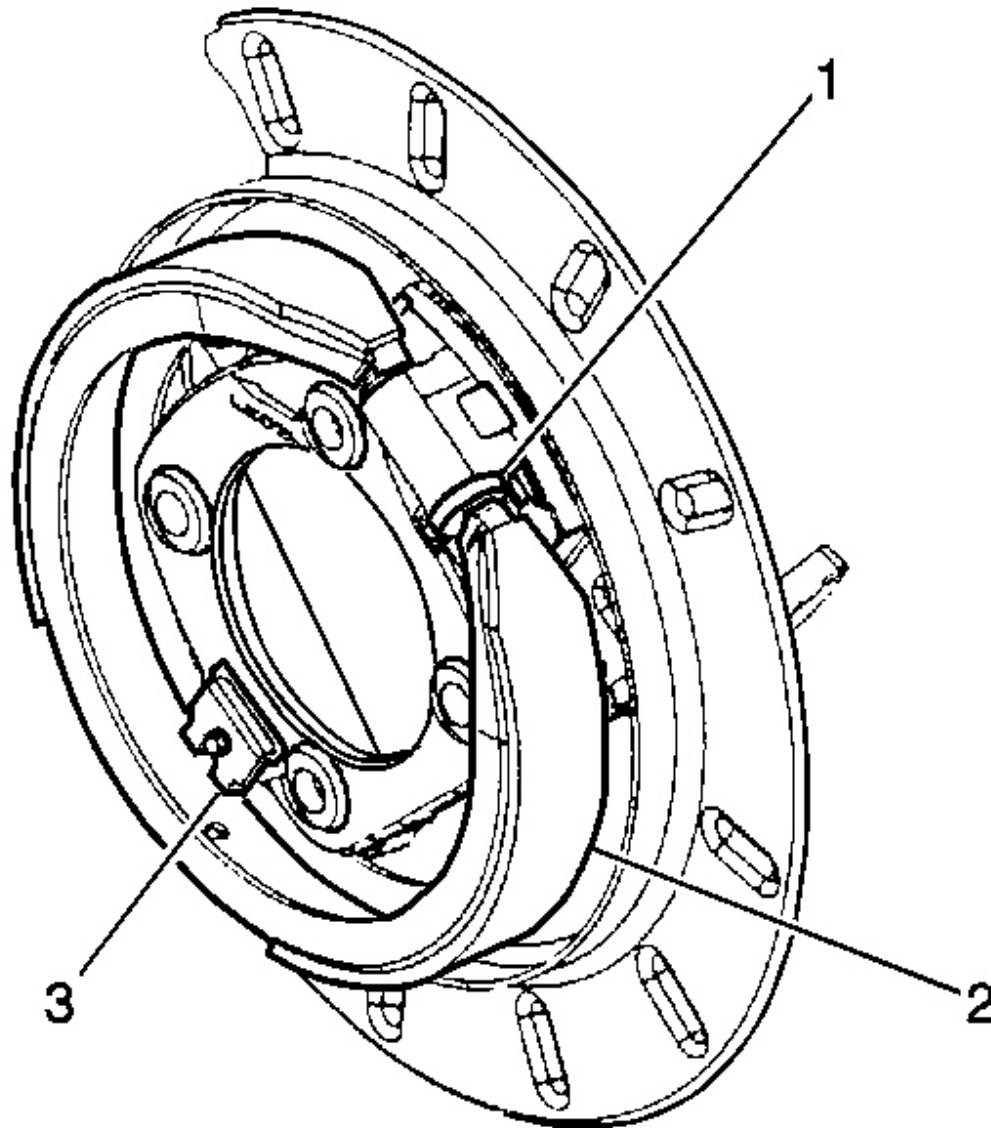

Fig. 9: Locating Adjustment Screw, Park Brake Shoe & Retaining Spring
Courtesy of GENERAL MOTORS CORP.

7. Slide the park brake shoe (2) down until it is disengaged from the hold down spring (3).
8. Lift the shoe (2) away from the backing plate and slide the shoe up, off of the actuation mechanism (1).
9. Remove the shoe (2) over the axle flange and from the vehicle.
10. Clean the debris and the dust from the park brake components using a clean towel.

2004 Isuzu Ascender LS

2004 BRAKES Park Brake - Ascender

11. Turn the adjustment screw to the fully home position in the notched adjustment nut, then back it off 1/4 turn.
12. Align the slots in both the adjusting screw and tappet to be parallel with the backing plate face.
13. Using denatured alcohol, clean the rear backing plate of dirt and foreign materials.
14. Using non-lubricated, filtered air, dry the backing plate.

Installation Procedure

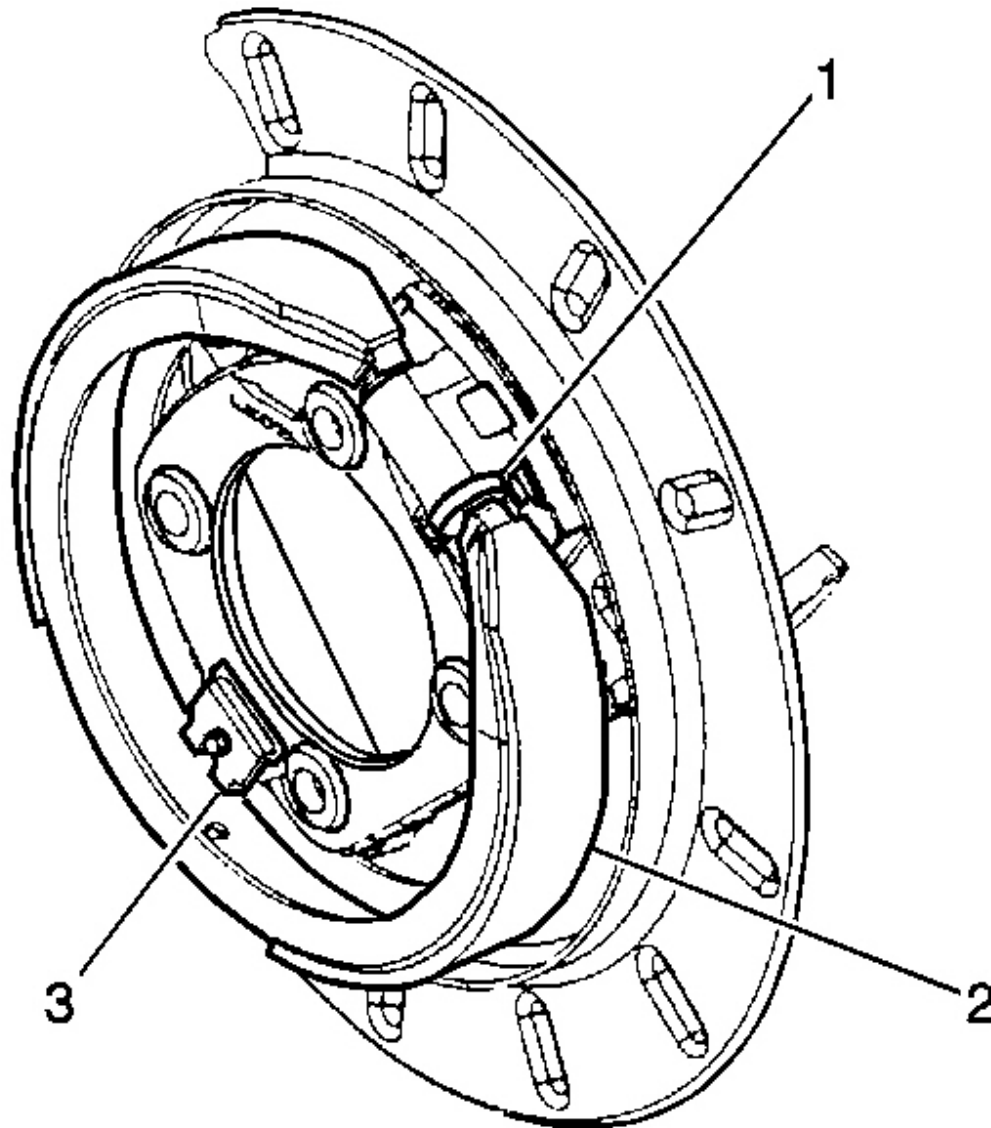

Fig. 10: Locating Adjustment Screw, Park Brake Shoe & Retaining Spring
Courtesy of GENERAL MOTORS CORP.

1. Install a new park brake shoe (2) over the axle flange.
2. Position the shoe (2) on the actuation mechanism.
3. Holding the lower end of the shoe (2) away from the backing plate, slide the shoe down, over the top of the hold down spring (3).

2004 Isuzu Ascender LS

2004 BRAKES Park Brake - Ascender

4. Place the lower end of the shoe (2) against the backing plate.
5. Slide the shoe (2) up and under the hold down spring (3).
6. Inspect the position of the shoe assembly. The shoe must be central on the backing plate and with both tips located in the slots of the actuation mechanism (1).
7. Manually check the park brake for proper operation by moving the park brake actuator lever and observing the movement of the actuation mechanism.

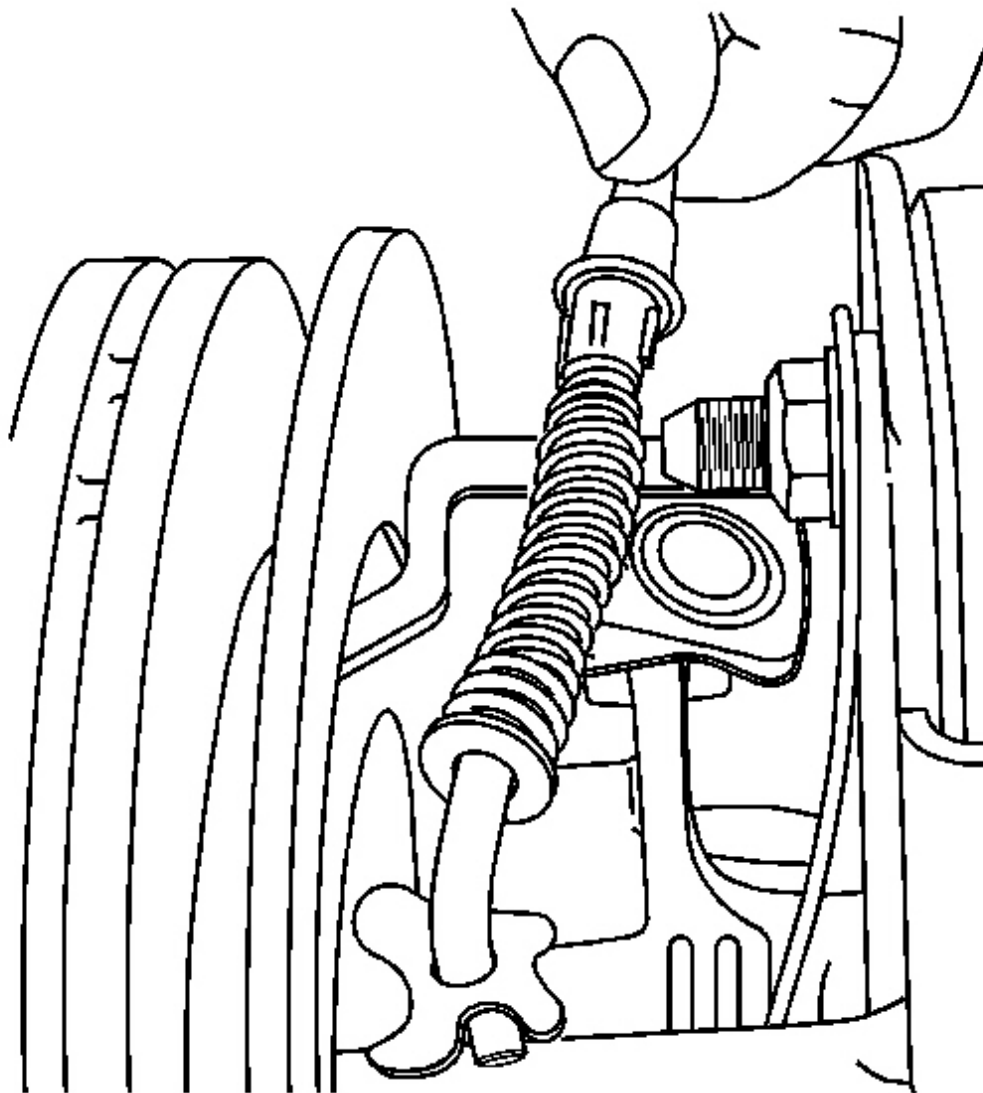

Fig. 11: View Of Parking Brake Cable
Courtesy of GENERAL MOTORS CORP.

8. Install the park brake cable to the park brake lever.

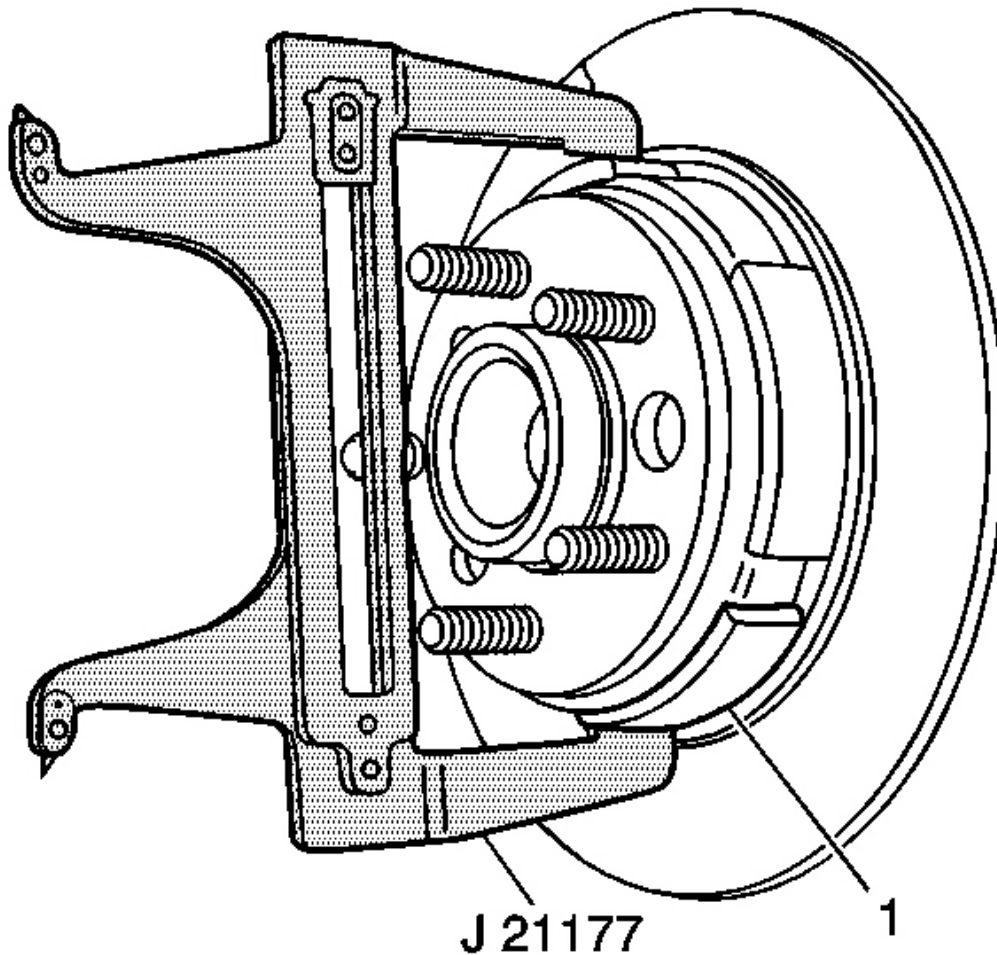

Fig. 12: Adjusting Parking Brake Shoes Using Special Tool
Courtesy of GENERAL MOTORS CORP.

9. Adjust the park brake shoe (1). Refer to **Park Brake Adjustment**.

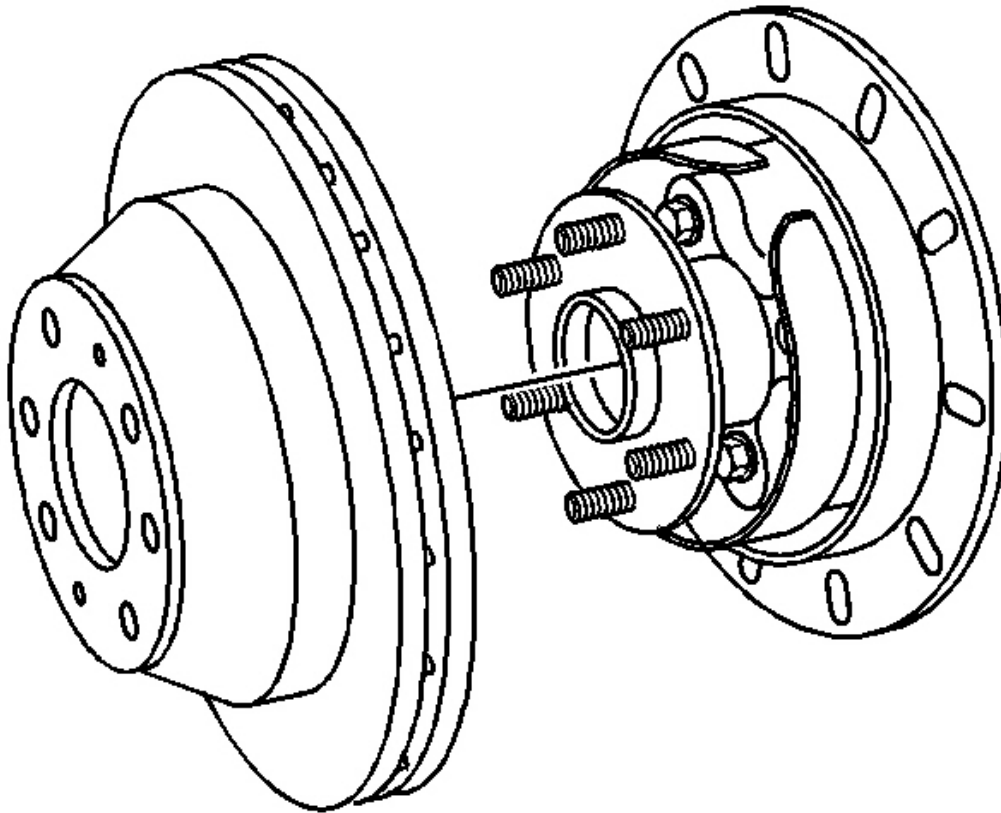

Fig. 13: View Of Rotor To Hub
Courtesy of GENERAL MOTORS CORP.

10. Install the brake rotor.

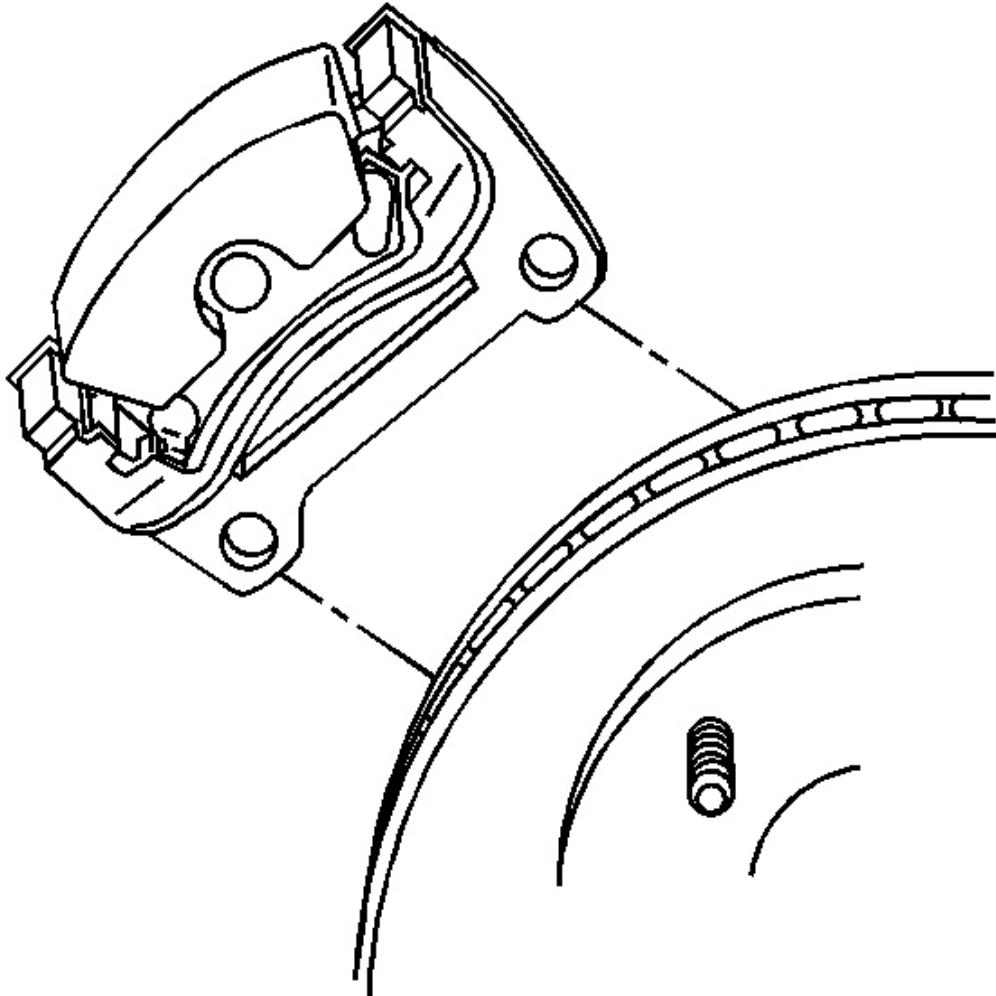

Fig. 14: View Of Caliper Bracket
Courtesy of GENERAL MOTORS CORP.

11. Install the brake caliper and mounting bracket. Refer to **Brake Caliper Bracket Replacement - Rear** .
12. Install the tire and wheel. Refer to **Tire and Wheel Removal and Installation** in Suspension
13. Lower the vehicle. Refer to **Lifting and Jacking the Vehicle** in General Information.

PARK BRAKE LEVER ASSEMBLY REPLACEMENT

Removal Procedure

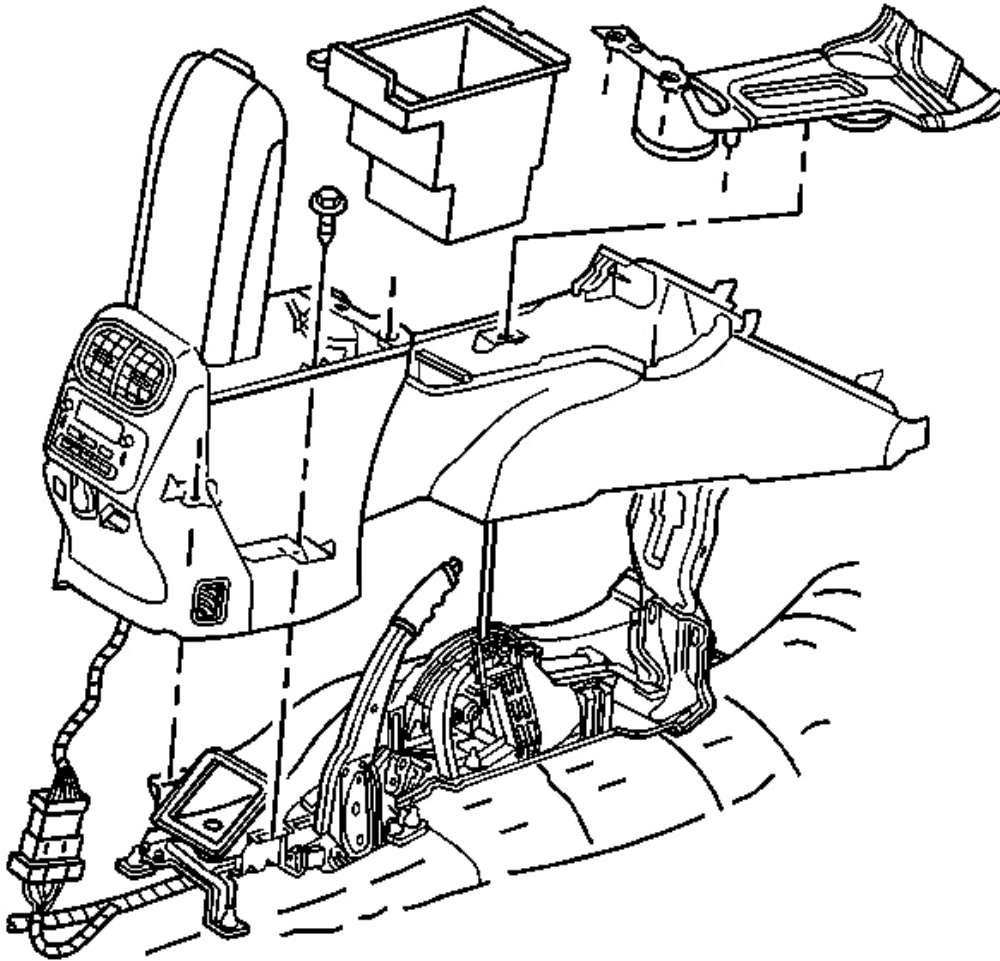

Fig. 15: Identifying Console Assembly
Courtesy of GENERAL MOTORS CORP.

1. Remove the floor console. Refer to **Console Replacement** in Instrument Panel, Gages and Console.
2. Disable the Park Brake Automatic Adjuster. Refer to **Disabling the Park Brake Cable Automatic Adjuster**.
3. Raise and suitably support the vehicle. Refer to **Lifting and Jacking the Vehicle** in General Information.

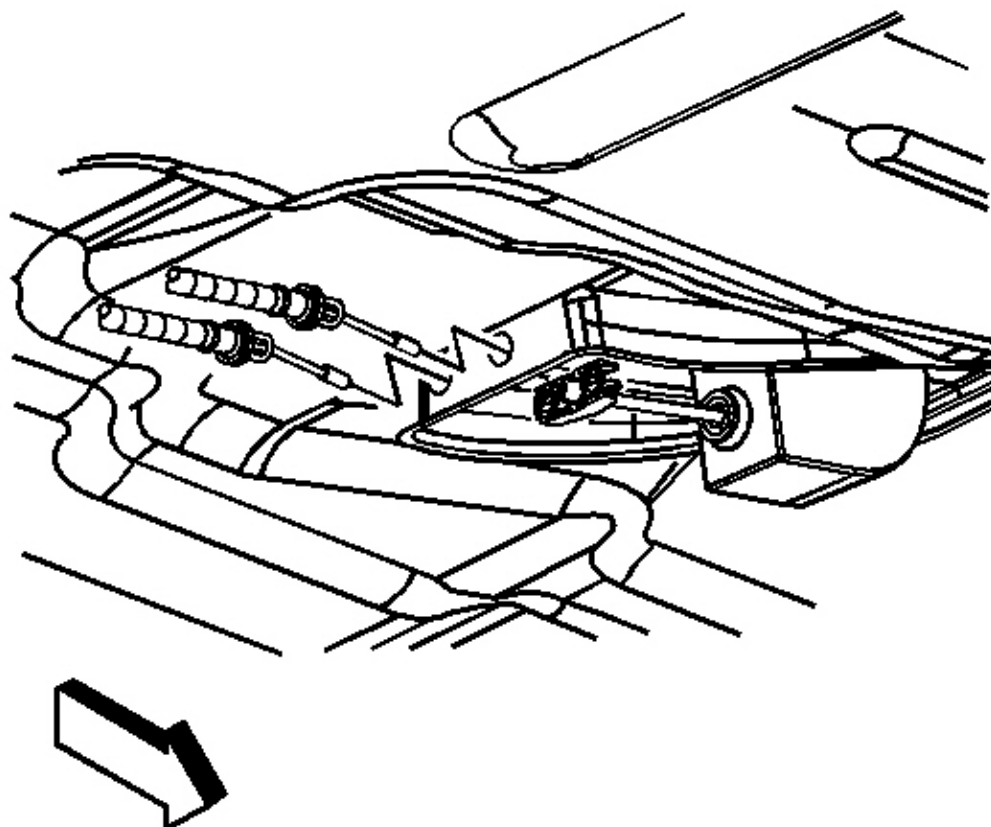

Fig. 16: Park Brake Cables From Equalizer
Courtesy of GENERAL MOTORS CORP.

4. Disconnect the park brake cables from the equalizer.
5. Lower the vehicle.
6. Disconnect the electrical connector from the park brake warning lamp switch.

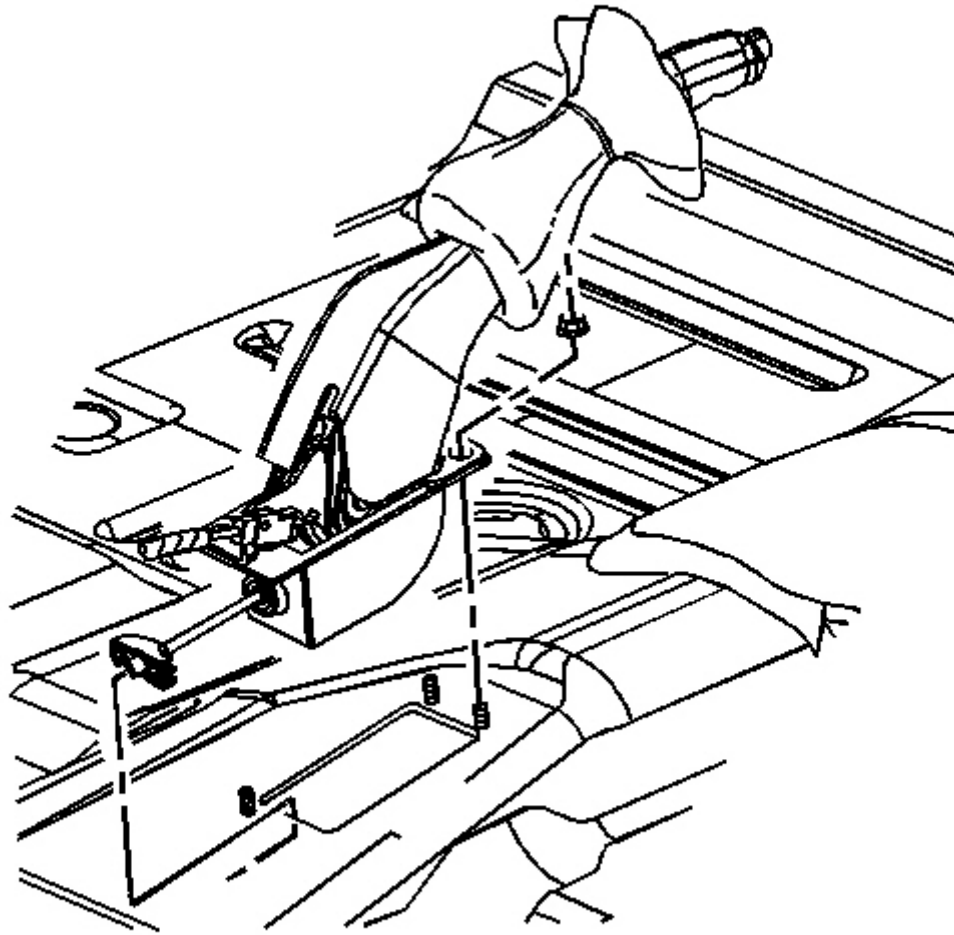

Fig. 17: Removing/Installing Park Brake Lever And Retaining Nut
Courtesy of GENERAL MOTORS CORP.

7. Remove the remaining park brake lever retaining nut.
8. Remove the park brake lever assembly from the vehicle.

Installation Procedure

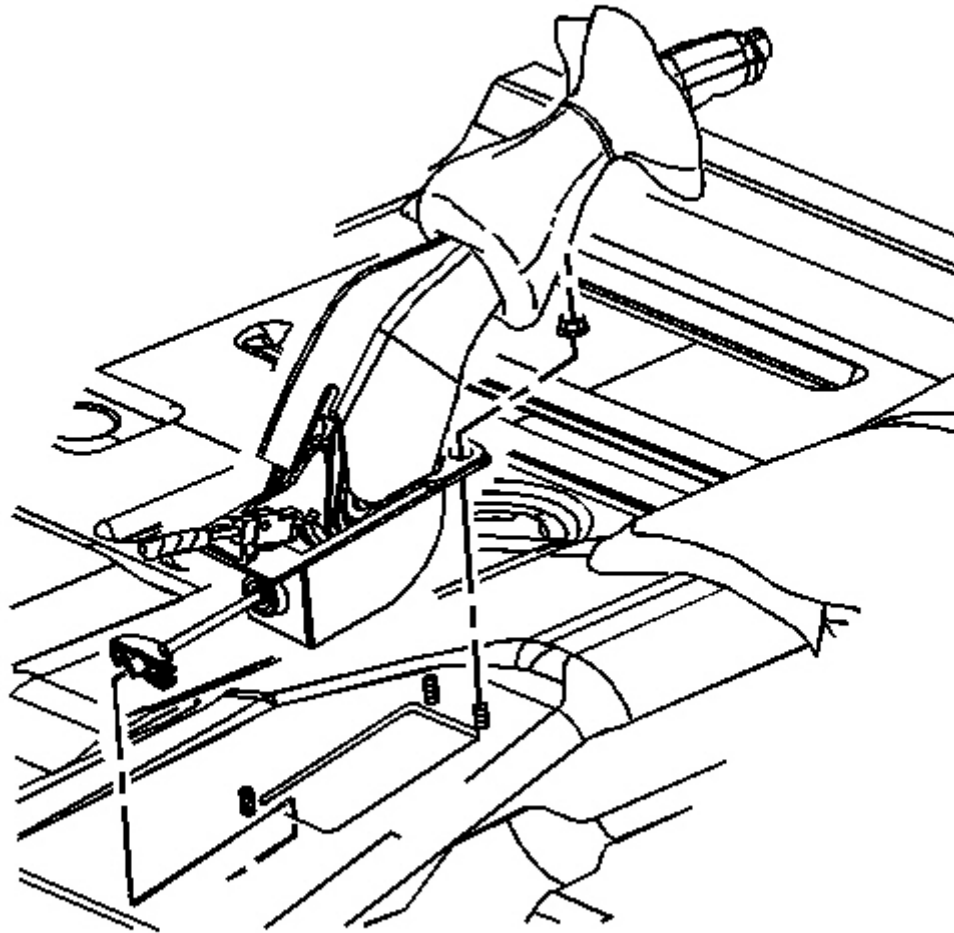

Fig. 18: Removing/Installing Park Brake Lever And Retaining Nut
Courtesy of GENERAL MOTORS CORP.

1. Install the park brake lever assembly to the vehicle.

NOTE: Refer to Fastener Notice in Cautions and Notices.

2. Install the right front park brake lever retaining nut.

Tighten: Tighten the park brake lever mounting nut to 25 N.m (18 lb ft).

3. Connect the electrical connector to the park brake warning lamp switch.

4. Raise the vehicle.

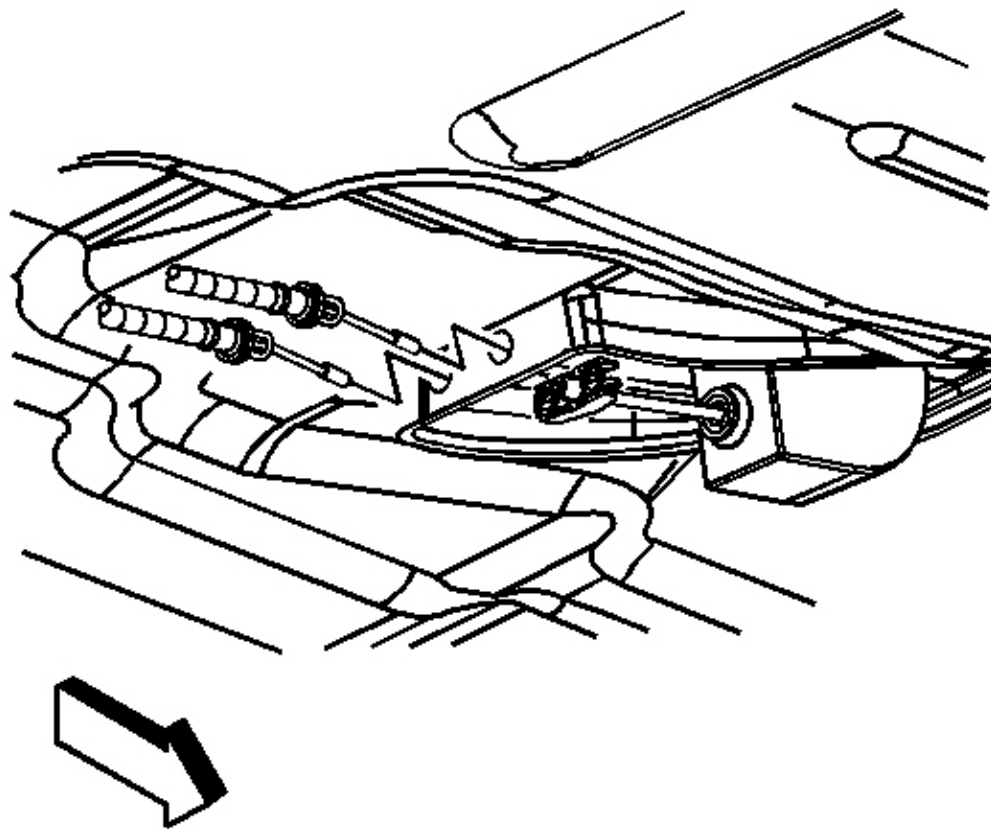

Fig. 19: Park Brake Cables From Equalizer
Courtesy of GENERAL MOTORS CORP.

5. Connect the park brake cables to the equalizer.
6. Lower the vehicle.

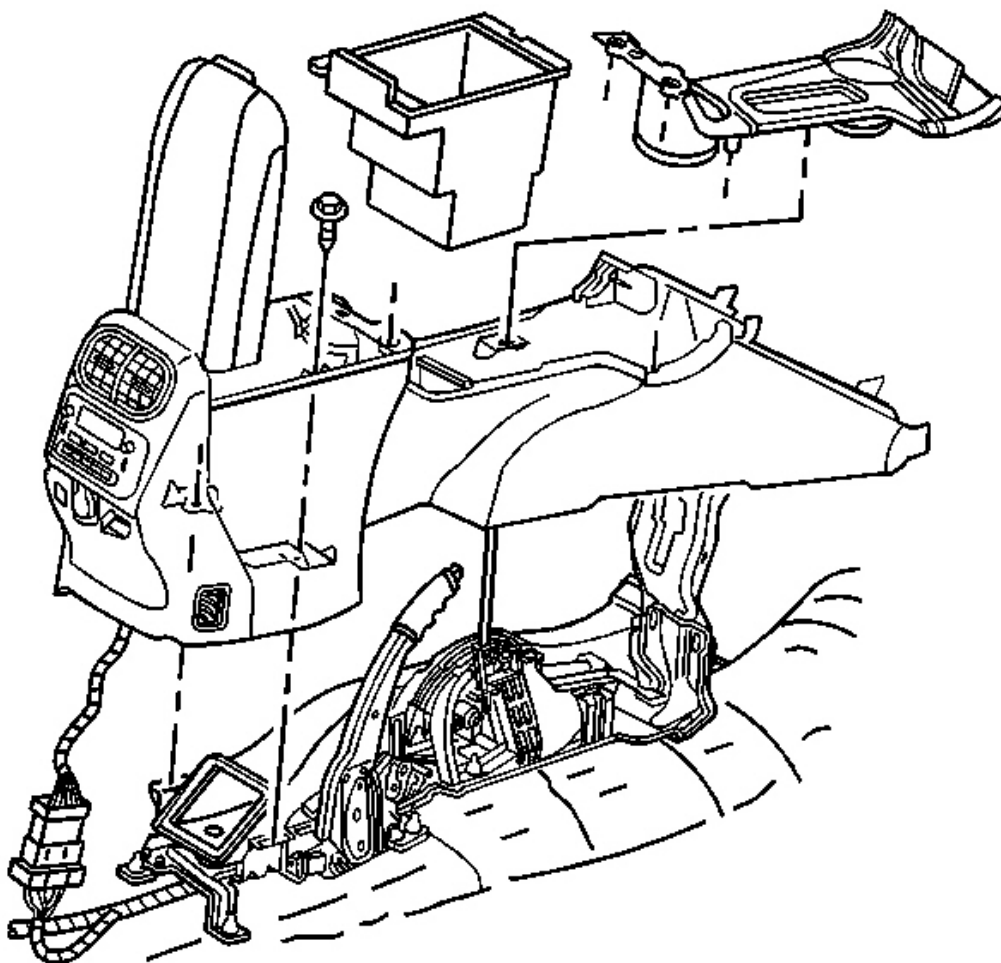

Fig. 20: Identifying Console Assembly
Courtesy of GENERAL MOTORS CORP.

7. Install the floor console. Refer to **Console Replacement** in Instrument Panel, Gages and Console.
8. Enable the park brake automatic adjuster. Refer to **Enabling the Park Brake Cable Automatic Adjuster**.

PARK BRAKE WARNING LAMP SWITCH REPLACEMENT

Removal Procedure

2004 Isuzu Ascender LS

2004 BRAKES Park Brake - Ascender

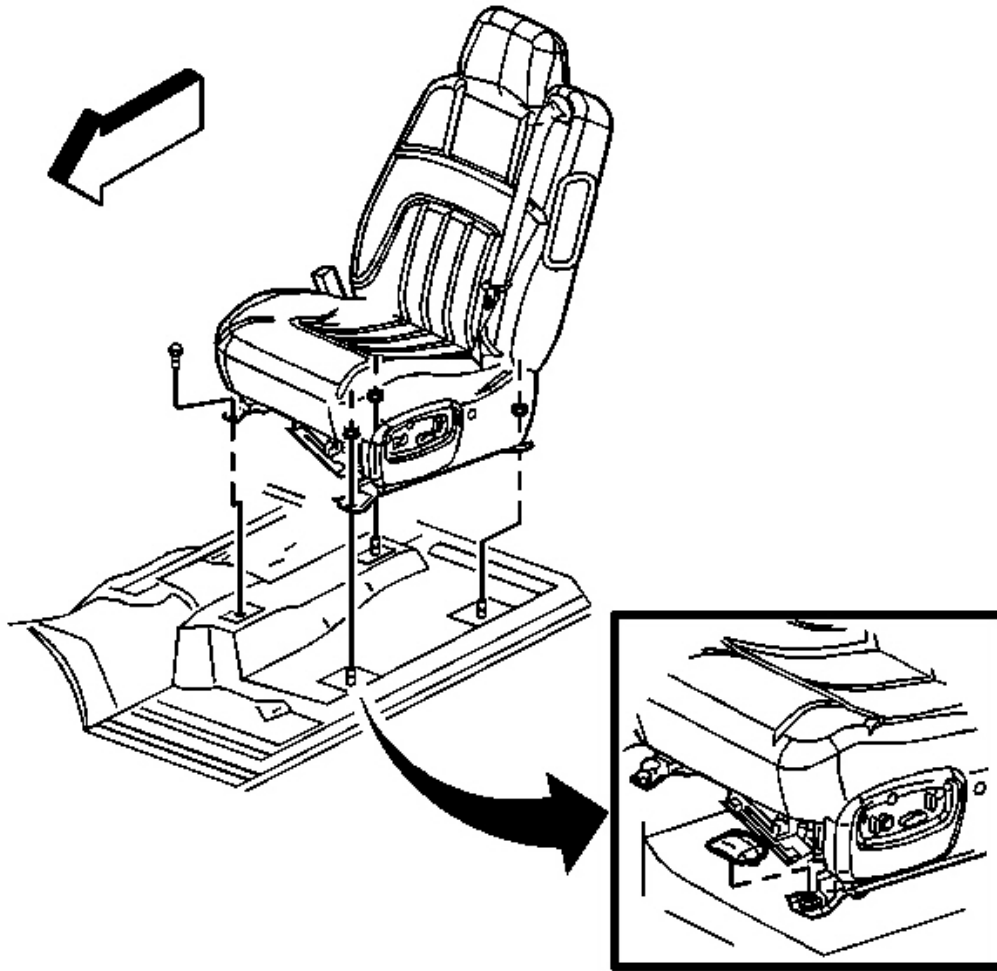

Fig. 21: Removing/Installing Front Passenger Side Seat
Courtesy of GENERAL MOTORS CORP.

1. Remove the front passenger side seat. Refer to **Seat Replacement - Front Bucket** in Seats.

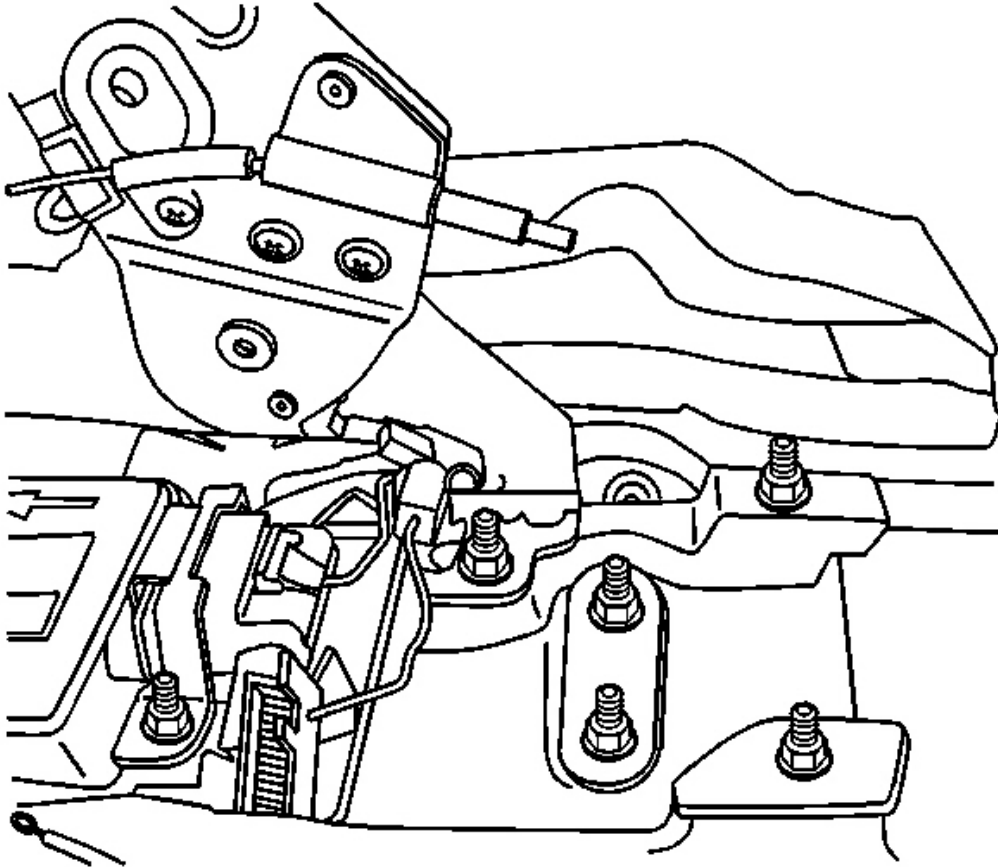

Fig. 22: Park Brake Warning Lamp Switch, Retaining Screw And Electrical Connector
Courtesy of GENERAL MOTORS CORP.

2. Remove the park brake warning lamp switch electrical connector.
3. Remove the park brake warning lamp switch retaining screw.
4. Remove the park brake warning lamp switch from the vehicle.

Installation Procedure

1. Install the park brake warning lamp switch.

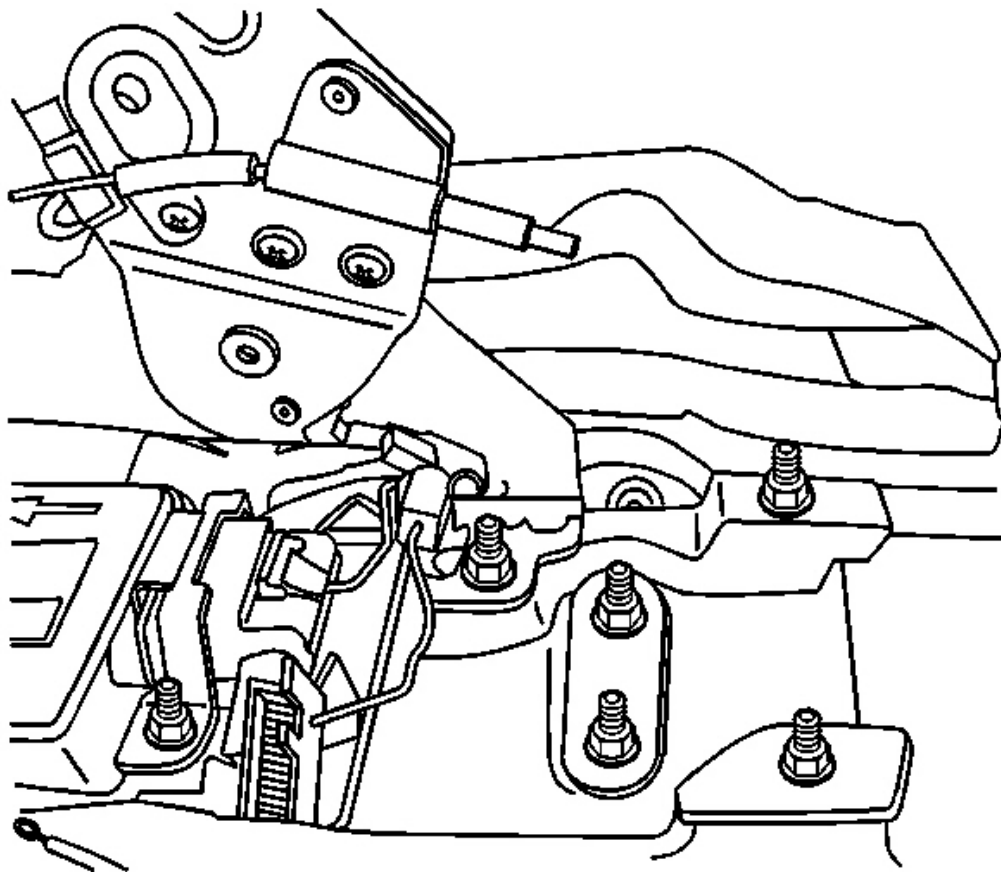

Fig. 23: Park Brake Warning Lamp Switch, Retaining Screw And Electrical Connector
Courtesy of GENERAL MOTORS CORP.

NOTE: Refer to Fastener Notice in Cautions and Notices.

2. Install the park brake warning lamp switch retaining screw.

Tighten: Tighten the park brake warning lamp switch mounting bolt to 4 N.m (35 lb in).

3. Connect the electrical connector.

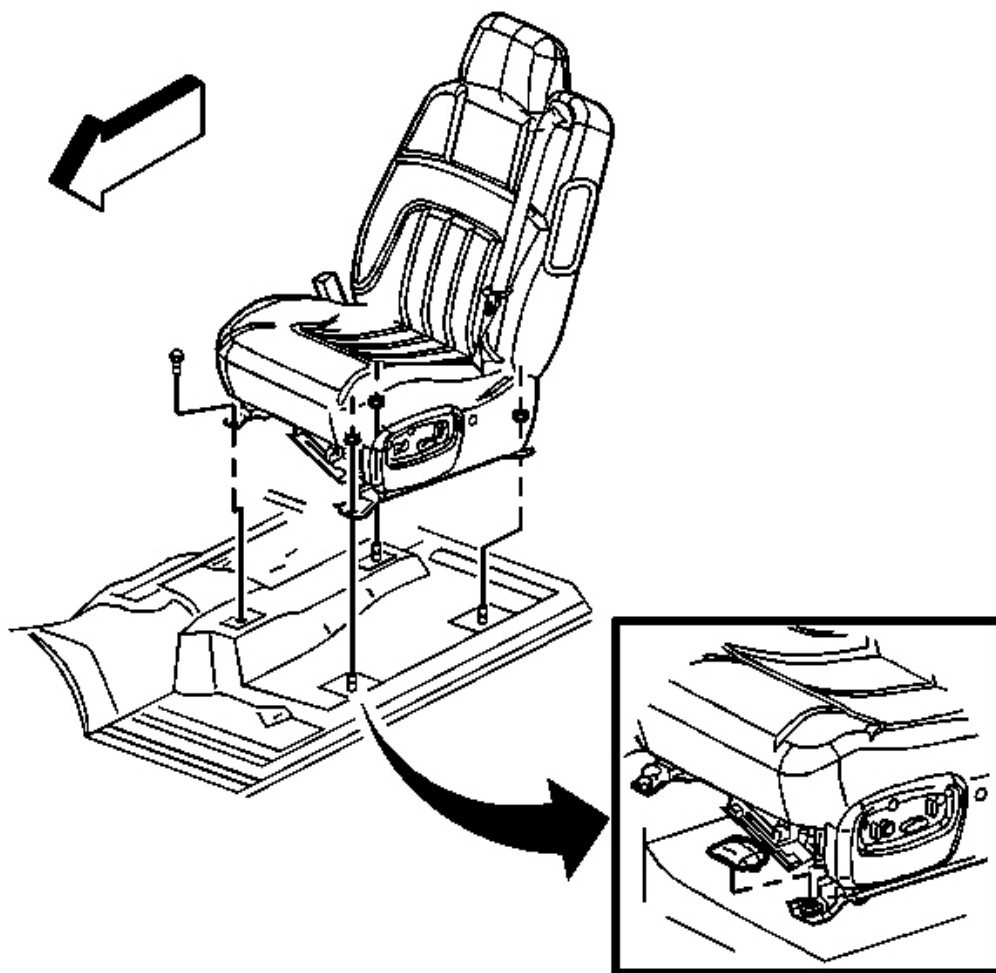

Fig. 24: Removing/Installing Front Passenger Side Seat
Courtesy of GENERAL MOTORS CORP.

4. Install the front passenger side seat. Refer to **Seat Replacement - Front Bucket** in Seats.

PARK BRAKE CABLE REPLACEMENT

Removal Procedure

Tools Required

J 37043 Parking Brake Cable Release Tool. See **Special Tools and Equipment**.

NOTE: Handling the parking brake cables during service requires extra care. Damage to the nylon coating reduces the corrosion protection. If the damage area passes through the nylon coating, increased parking brake effort could result. Avoid contacting the protective coating with sharp-edge tools or the sharp surfaces of the vehicle underbody.

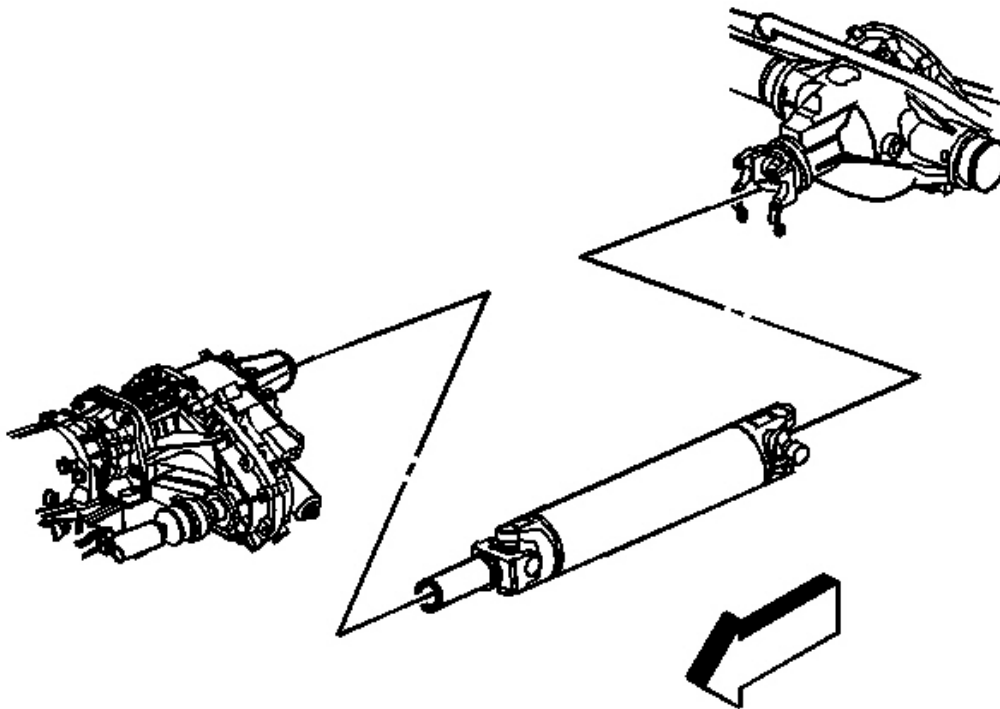

Fig. 25: Location Of Drive Shaft
Courtesy of GENERAL MOTORS CORP.

1. Disable the park brake automatic adjuster. Refer to **Disabling the Park Brake Cable Automatic Adjuster**.
2. Raise and suitably support the vehicle. Refer to **Lifting and Jacking the Vehicle** in General Information.
3. Remove the rear propeller shaft. Refer to **Propeller Shaft Replacement - Rear** in Propeller Shaft.

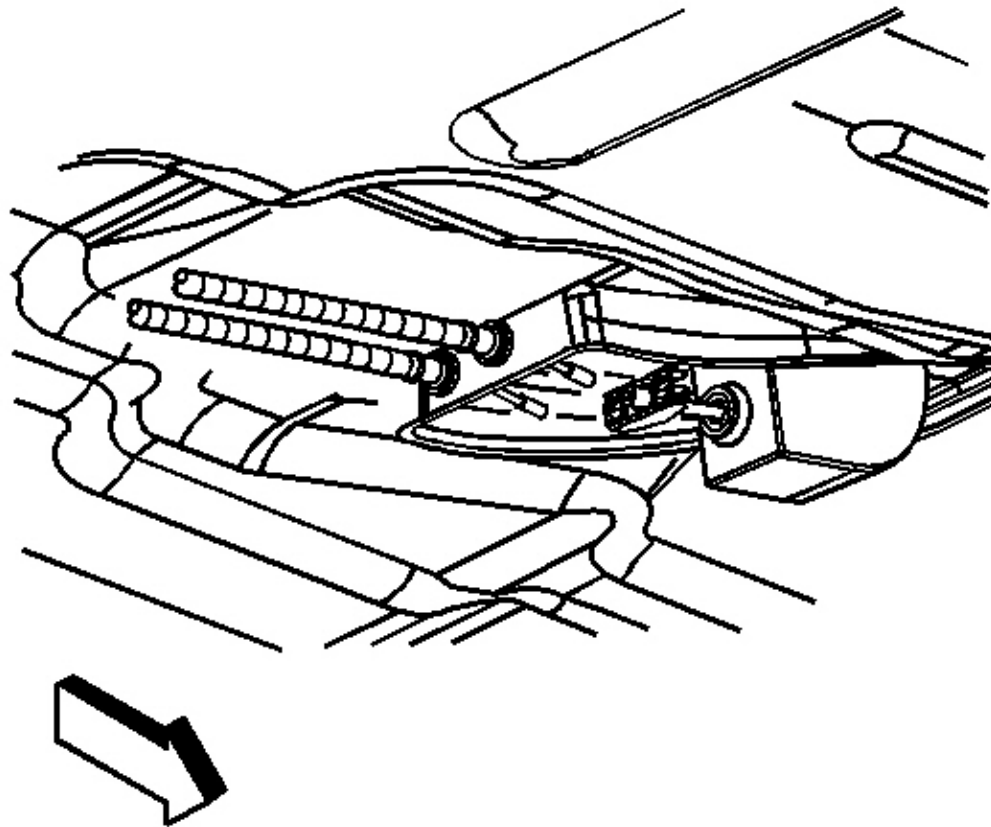

Fig. 26: Park Brake Cables From Parking Brake Equalizer
Courtesy of GENERAL MOTORS CORP.

4. Remove the park brake cables from the parking brake equalizer.

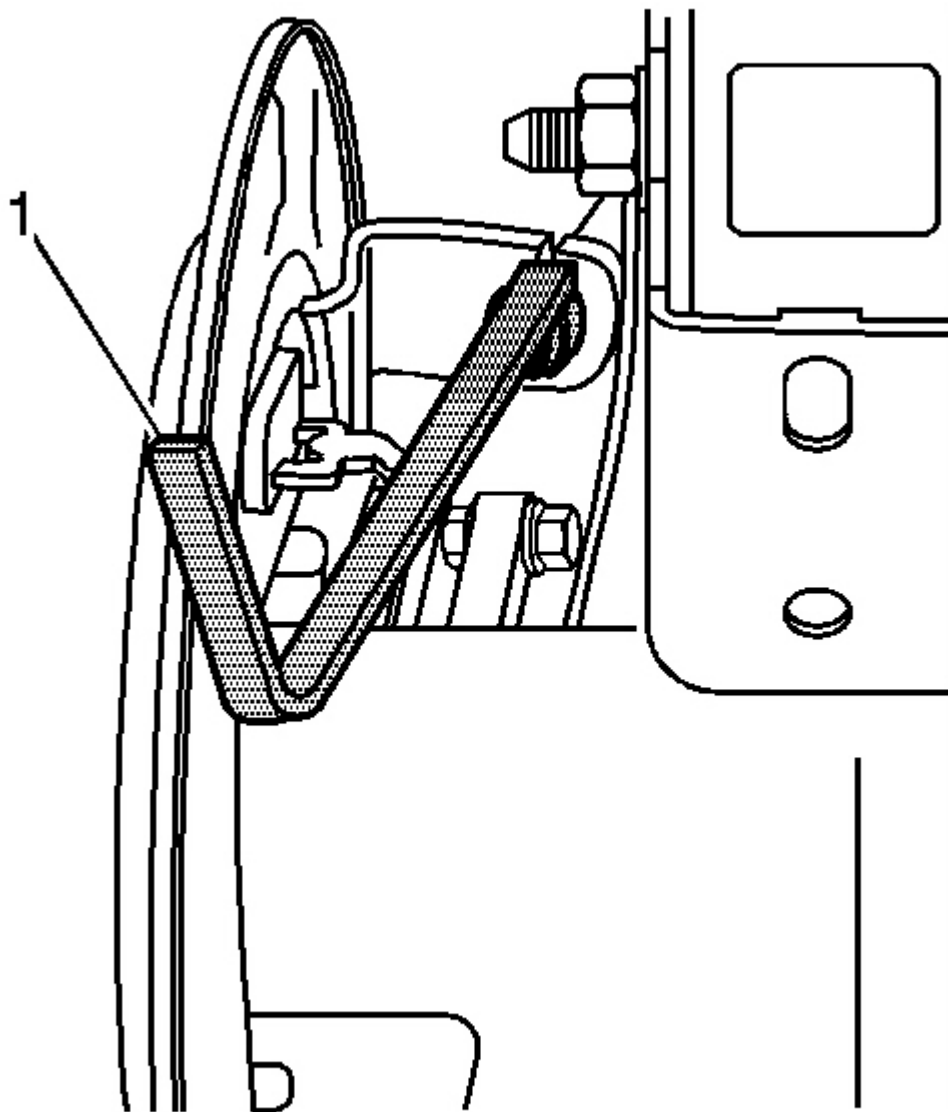

Fig. 27: Park Brake Cable Release Tool
Courtesy of GENERAL MOTORS CORP.

5. Using the **J 37043** (1), remove the park brake cable. See **Special Tools and Equipment**.

IMPORTANT: When serving the left park brake cable, the fuel tank **DOES NOT** have to be removed.

6. Install a pole jack with a block of wood under the fuel tank.

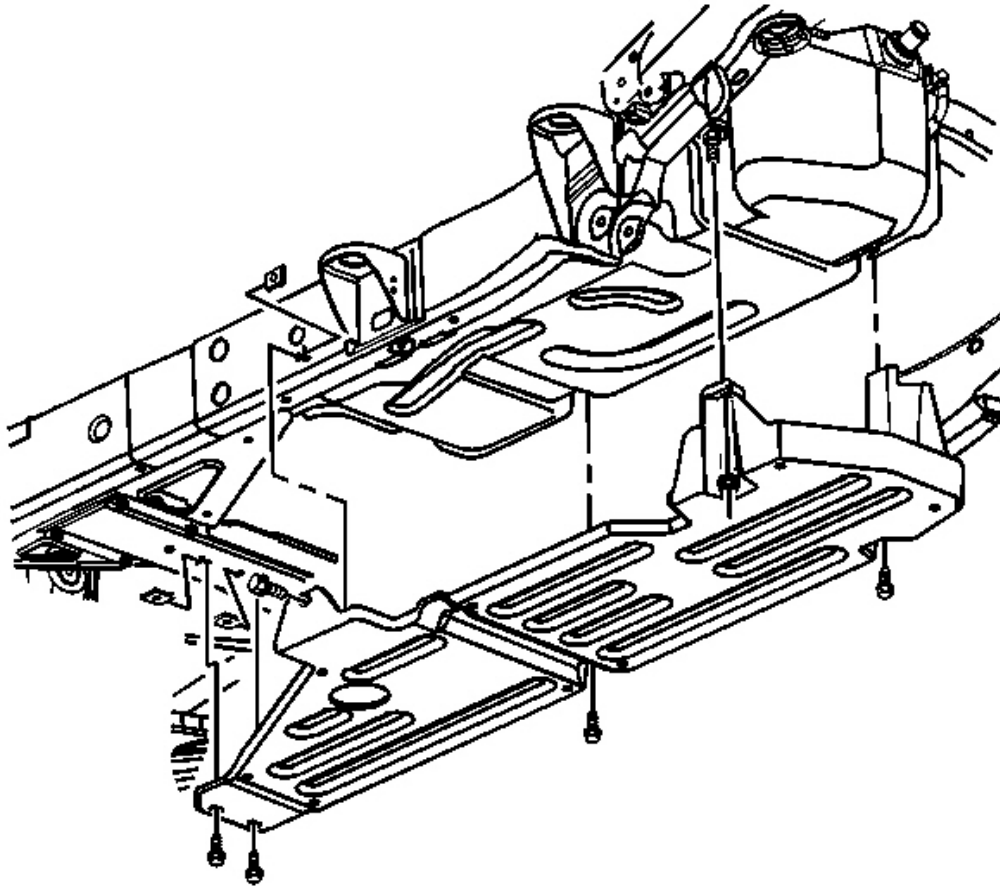

Fig. 28: Locating Fuel Tank Shield
Courtesy of GENERAL MOTORS CORP.

7. Remove the shield for the fuel tank. Refer to **Fuel Tank Shield Replacement (Short Wheelbase)** or **Fuel Tank Shield Replacement (Long Wheelbase)** in Frame and Underbody.
8. Remove the rear support bracket from the fuel tank.

IMPORTANT: When performing this service procedure, the fuel tank will only drop about four inches when supported by the pole jack. It is not necessary to lower the fuel tank any further than that.

9. Lower the fuel tank to allow access to the rear park brake cable retainer above the fuel tank.

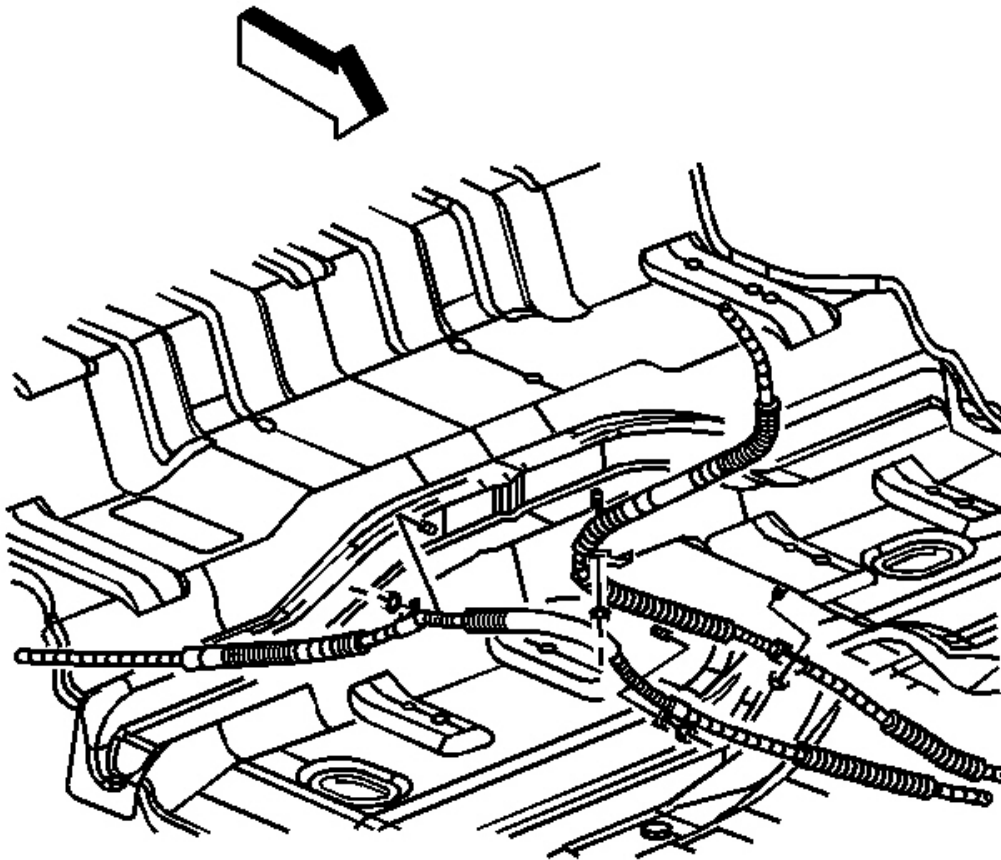

Fig. 29: Park Brake Cable Retaining Nuts View
Courtesy of GENERAL MOTORS CORP.

10. Remove the park brake cable retaining nuts from the underbody mounting studs.

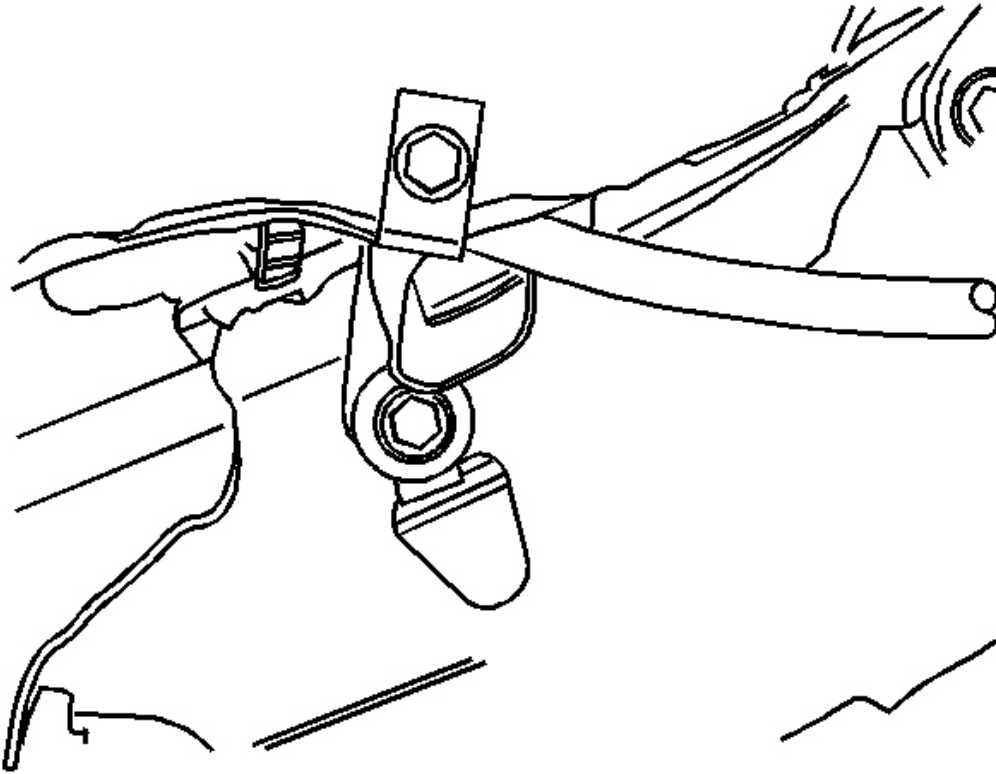

Fig. 30: Park Brake Cable And Park Brake Cable Retainers
Courtesy of GENERAL MOTORS CORP.

11. Remove the park brake cable from the park brake cable retainers, left rear shown.

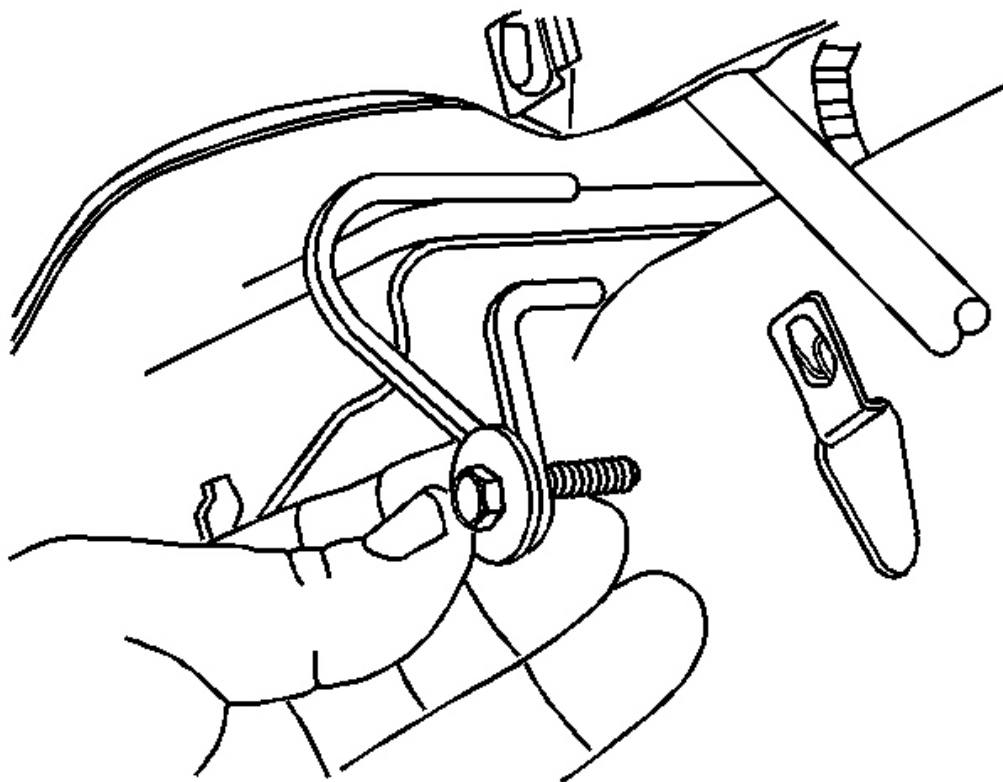

Fig. 31: Removing/Installing Park Brake Retaining Bracket Bolt
Courtesy of GENERAL MOTORS CORP.

12. Remove the park brake retaining bracket bolt from the frame.
13. Remove the park brake retainer from the frame, left rear shown.
14. Depress the retaining clips for the parking brake cable.
15. Remove the park brake from the mounting bracket.

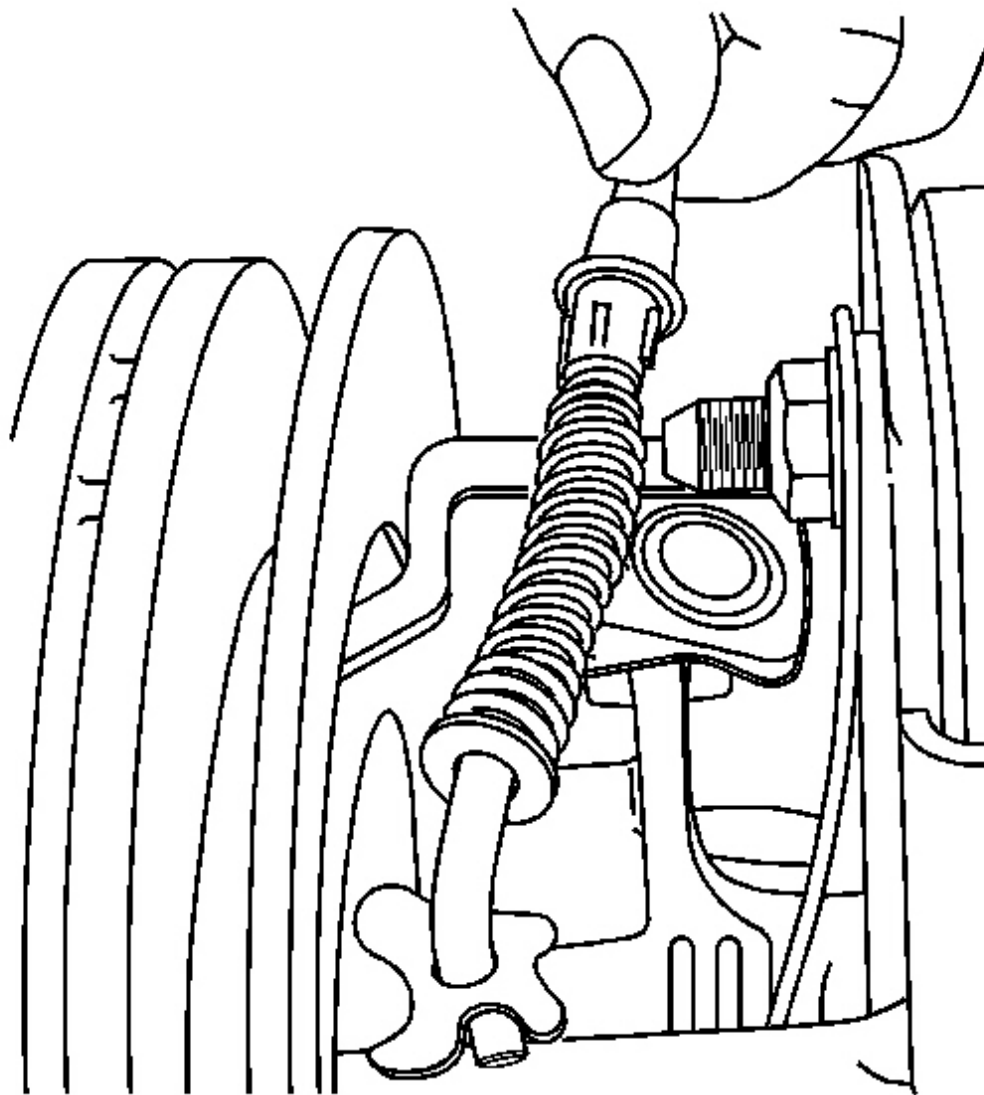

Fig. 32: View Of Parking Brake Cable
Courtesy of GENERAL MOTORS CORP.

16. Remove the park brake cable from the actuator.
17. Push the park brake cable through the frame toward the inside from the vehicle.
18. Remove the park brake cables from the vehicle.

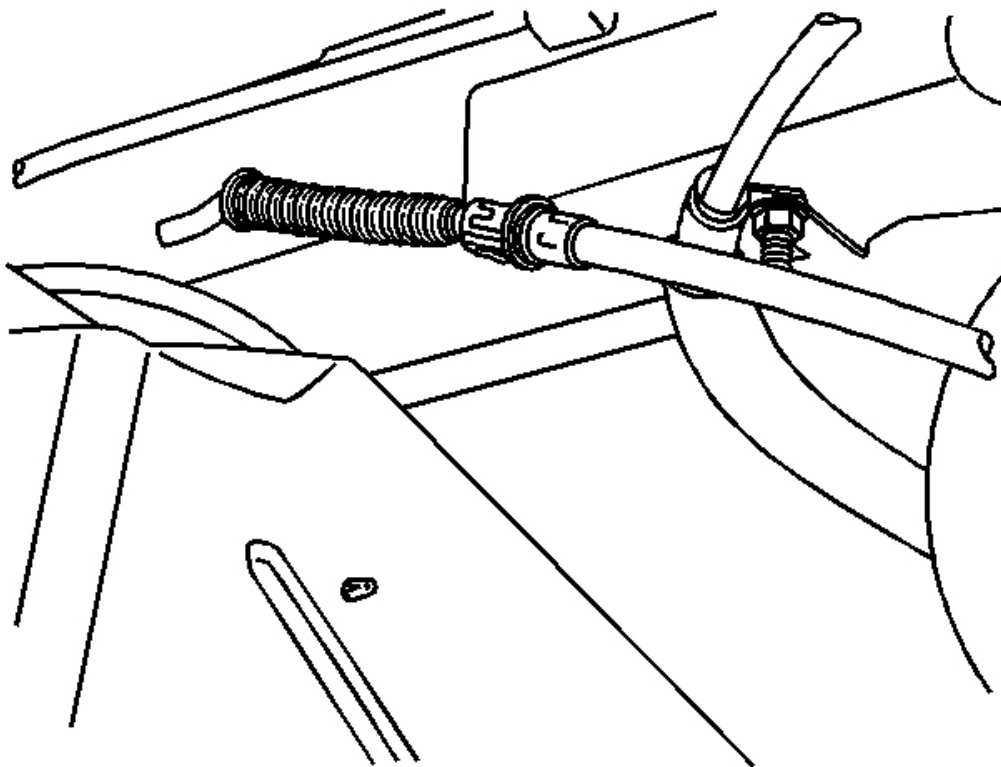

Fig. 33: Park Brake Cables Over Fuel Tank Assembly
Courtesy of GENERAL MOTORS CORP.

1. Install the park brake cables over the fuel tank assembly.

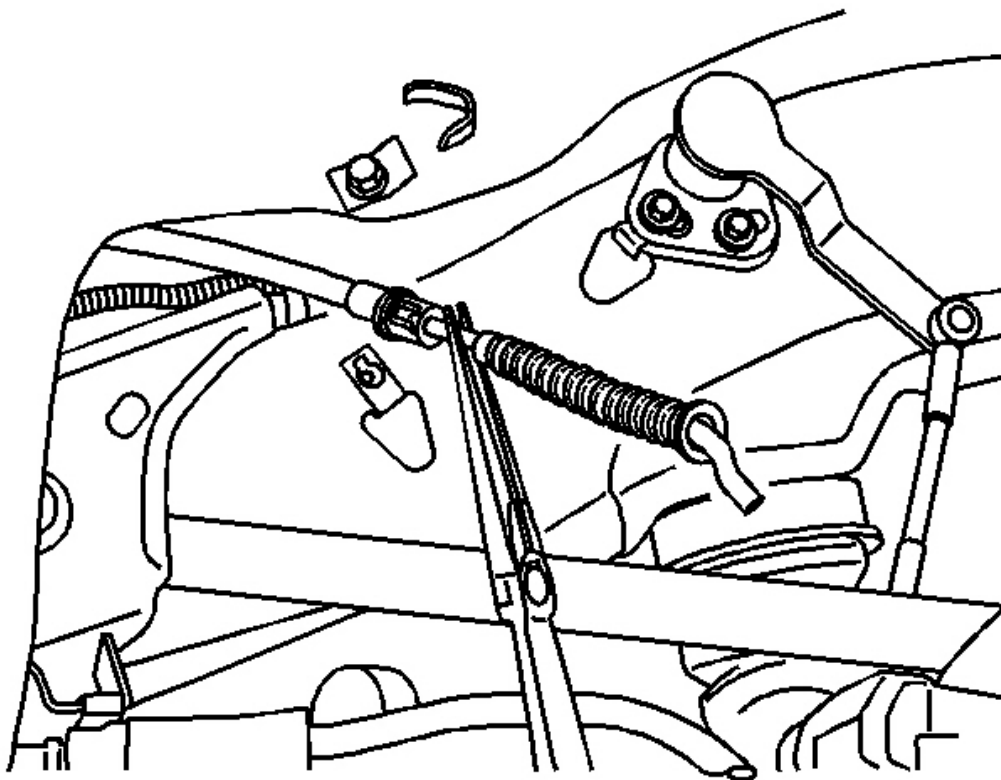

Fig. 34: Pulling Park Brake Cable Through Frame
Courtesy of GENERAL MOTORS CORP.

2. Pull the park brake cable through the frame toward the outside of the vehicle.

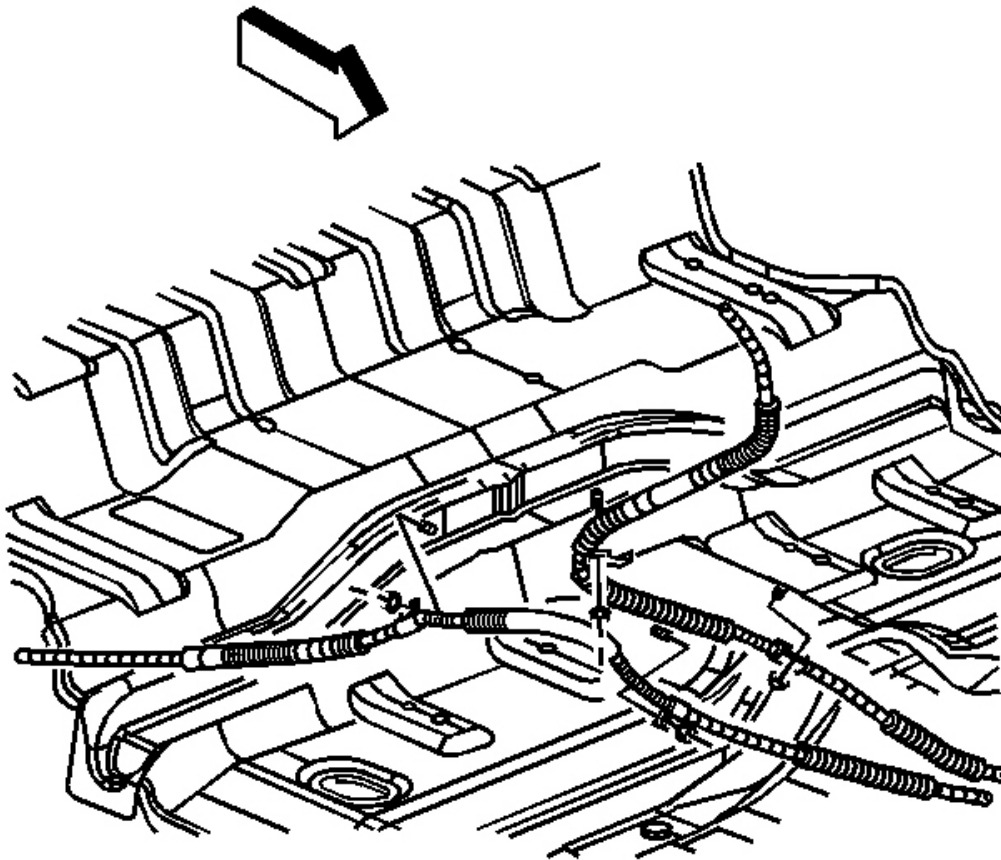

Fig. 35: Park Brake Cable Retaining Nuts View
Courtesy of GENERAL MOTORS CORP.

NOTE: Refer to Fastener Notice in Cautions and Notices.

3. Install the park brake cable retaining nuts to the underbody mounting studs.

Tighten: Tighten the park brake cable retaining nuts to 10 N.m (7 lb ft).

4. Raise the fuel tank the fuel tank.
5. Install the rear support bracket for the fuel tank.
6. Remove the pole jack and the block of wood from the fuel tank.

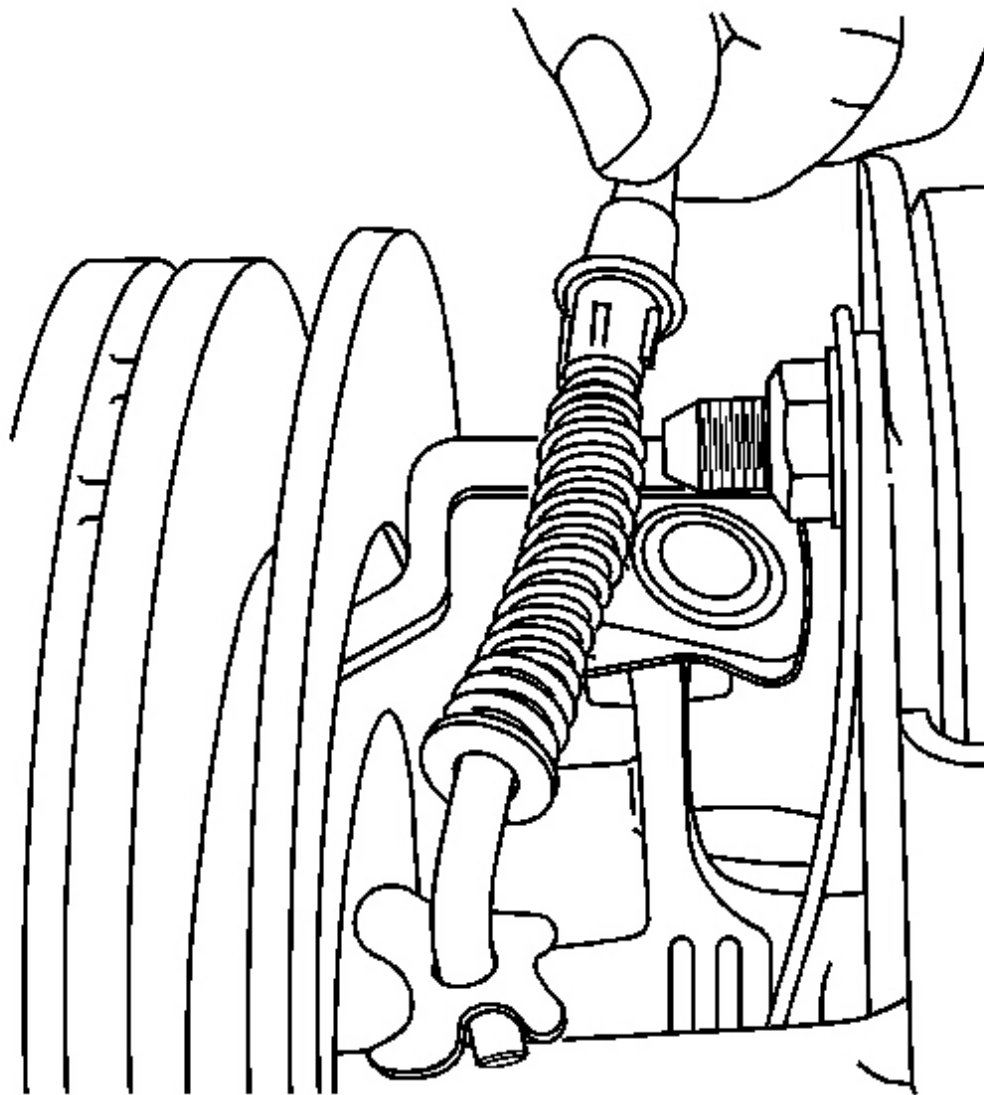

Fig. 36: View Of Parking Brake Cable
Courtesy of GENERAL MOTORS CORP.

7. Install the park brake cable on the actuator.
8. Depress the retaining clips for the park brake cable.

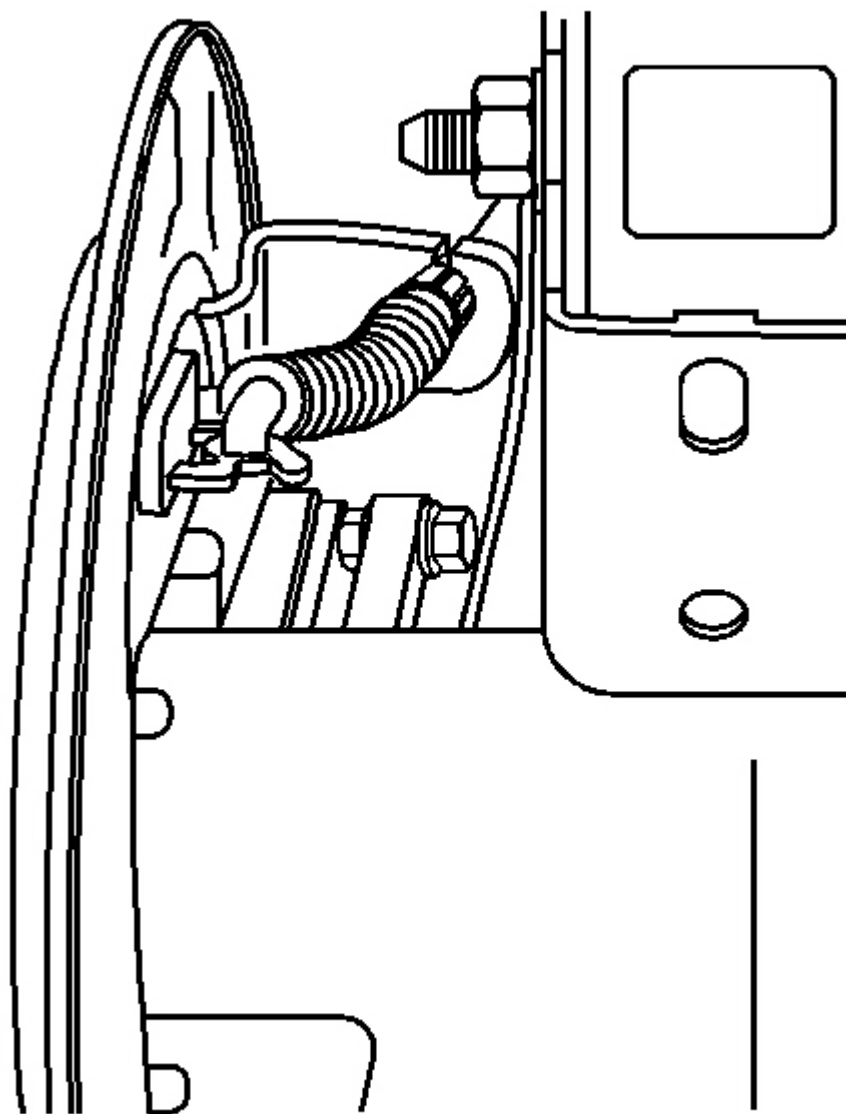

Fig. 37: Park Brake Retainer View
Courtesy of GENERAL MOTORS CORP.

9. Install the park brake retainer to the frame (left rear shown).

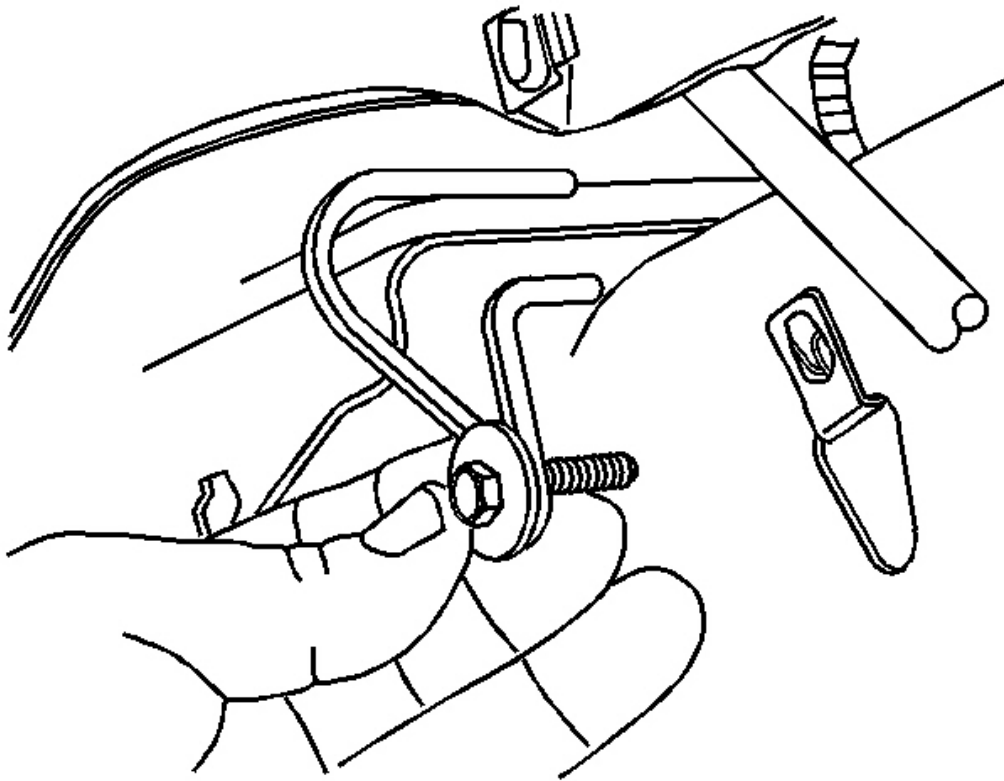

Fig. 38: Removing/Installing Park Brake Retaining Bracket Bolt
Courtesy of GENERAL MOTORS CORP.

10. Install the park brake retaining bracket bolt in the frame.

Tighten: Tighten park brake cable retaining bracket bolt to 20 N.m (15 lb ft).

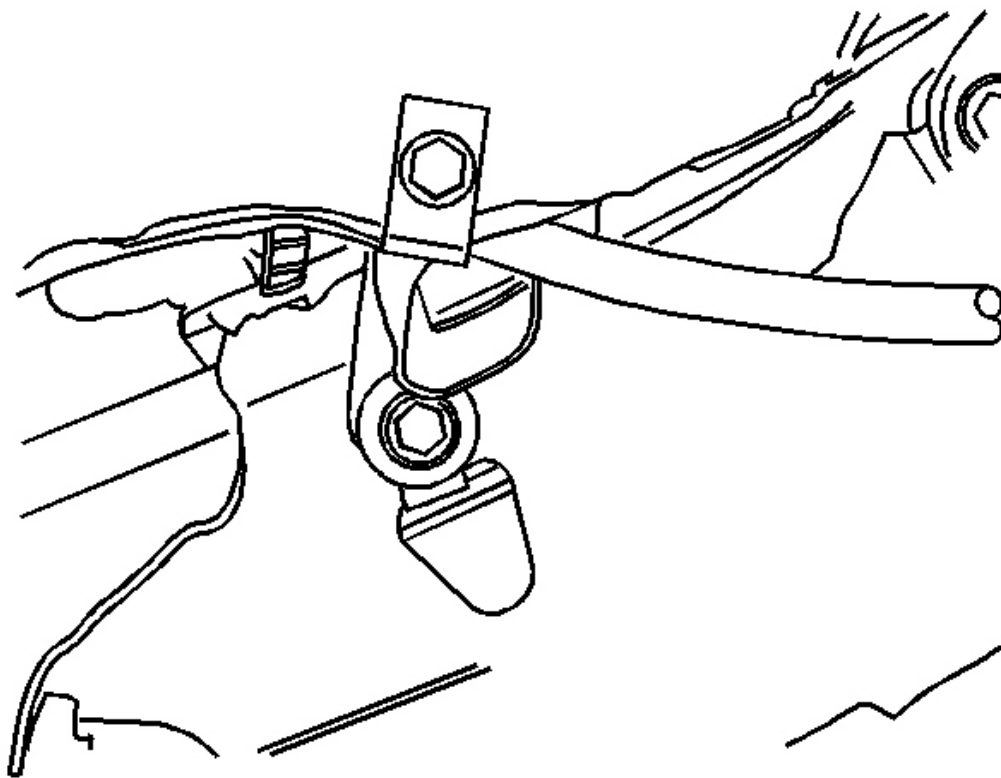

Fig. 39: Park Brake Cable And Park Brake Cable Retainers
Courtesy of GENERAL MOTORS CORP.

11. Install the park brake cable to the park brake cable retainers, left rear shown.

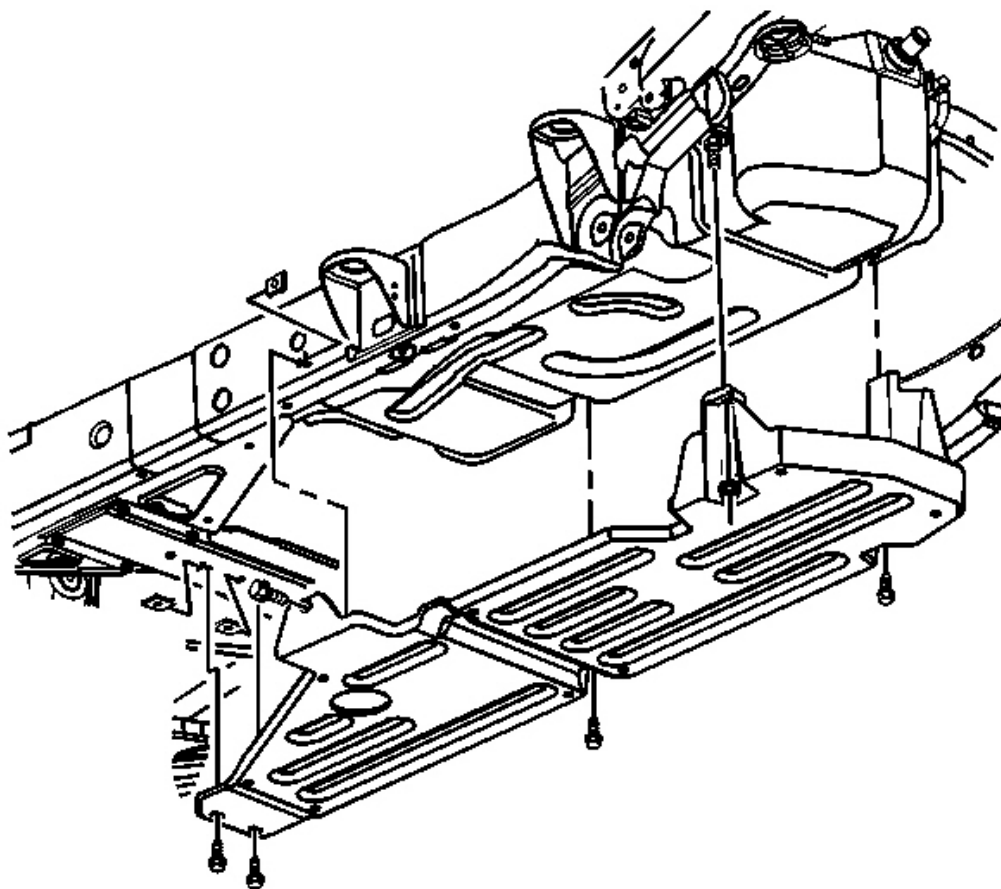

Fig. 40: Locating Fuel Tank Shield

Courtesy of GENERAL MOTORS CORP.

12. Install the shield for the fuel tank. Refer to **Fuel Tank Shield Replacement (Short Wheelbase)** or **Fuel Tank Shield Replacement (Long Wheelbase)** in Frame and Underbody.

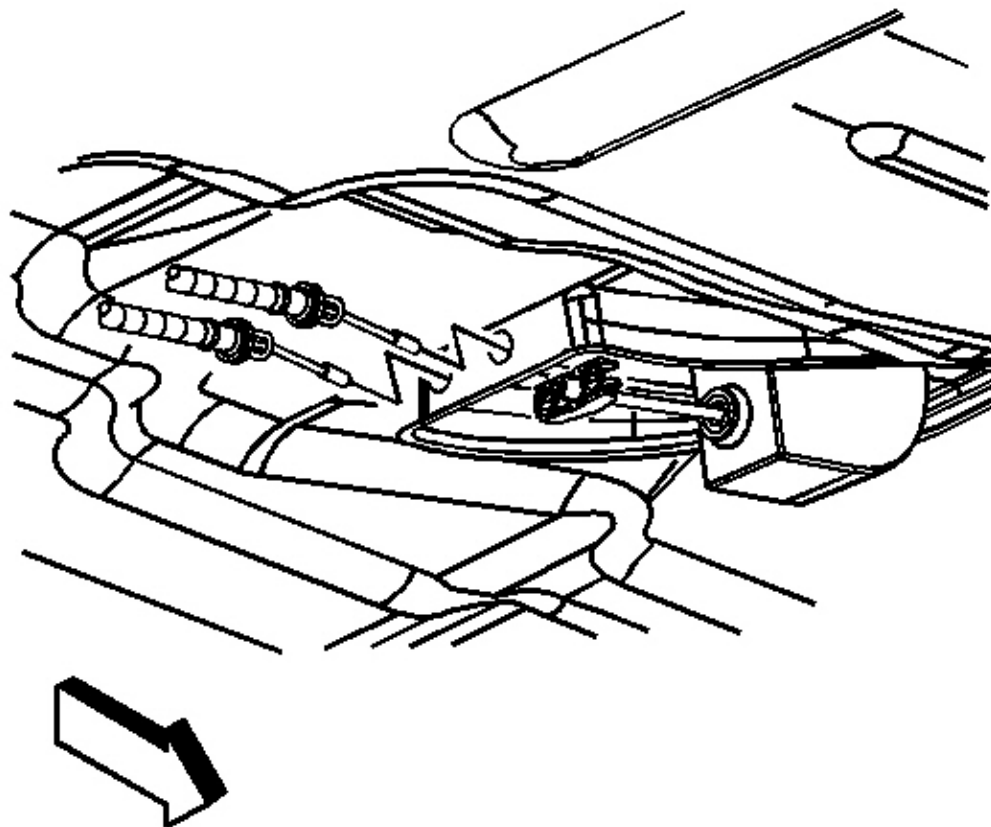

Fig. 41: Park Brake Cables From Equalizer
Courtesy of GENERAL MOTORS CORP.

13. Install the park brake cables to the retainer.

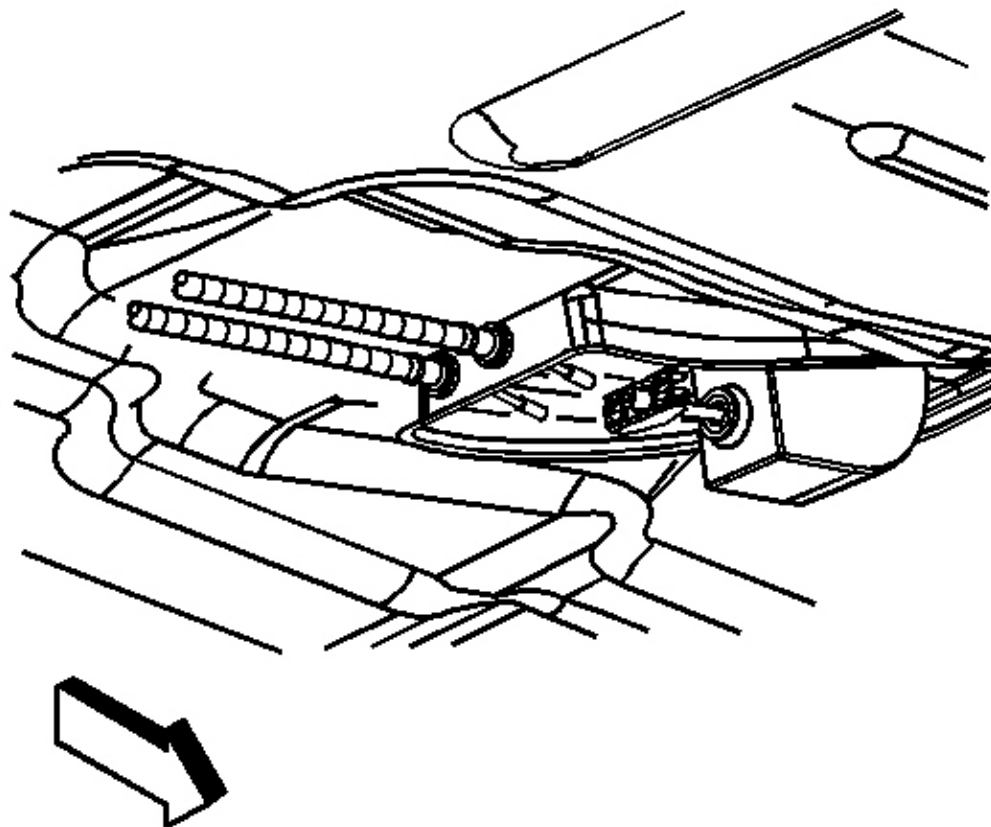

Fig. 42: Park Brake Cables From Parking Brake Equalizer
Courtesy of GENERAL MOTORS CORP.

14. Install the park brake cables to the park brake equalizer.

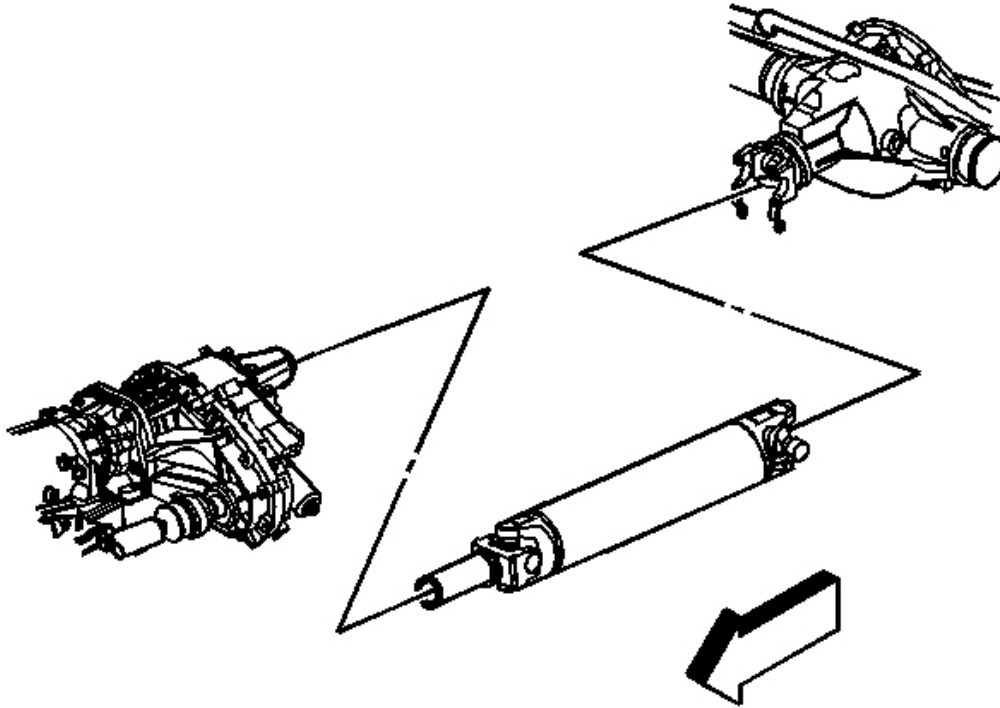

Fig. 43: Location Of Drive Shaft
Courtesy of GENERAL MOTORS CORP.

15. Install the rear propeller shaft. Refer to **Propeller Shaft Replacement - Rear** in Propeller Shaft.
16. Lower the vehicle. Refer to **Lifting and Jacking the Vehicle** in General Information.
17. Enable the park brake automatic adjuster. Refer to **Enabling the Park Brake Cable Automatic Adjuster**.
18. Test the park brake operation.
19. Adjust the park brake shoes. Refer to **Park Brake Adjustment**.

DISABLING THE PARK BRAKE CABLE AUTOMATIC ADJUSTER

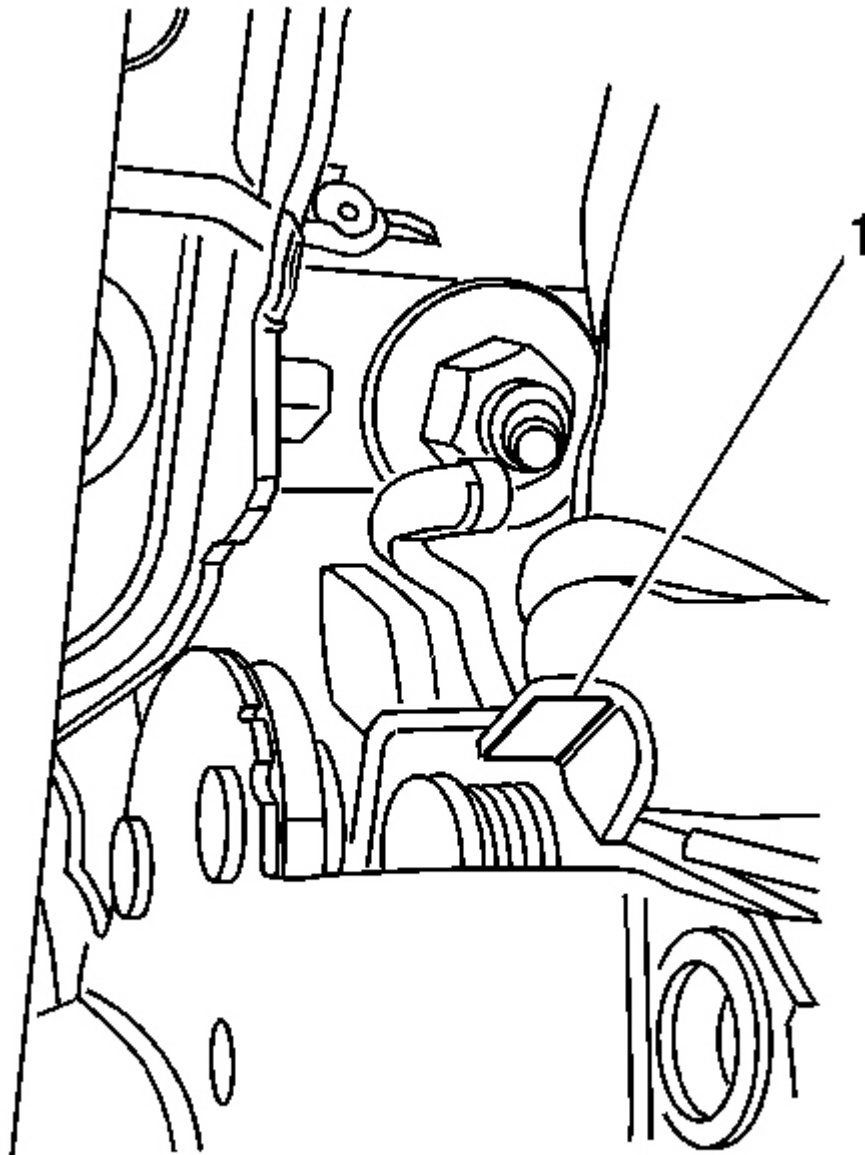

Fig. 44: Self-Adjust Clip

Courtesy of GENERAL MOTORS CORP.

1. Place the park brake lever in the full release position.
2. Raise and suitably support the vehicle. Refer to **Lifting and Jacking the Vehicle** in General Information.

2004 Isuzu Ascender LS

2004 BRAKES Park Brake - Ascender

NOTE: Handling the parking brake cables during service requires extra care. Damage to the nylon coating reduces the corrosion protection. If the damage area passes through the nylon coating, increased parking brake effort could result. Avoid contacting the protective coating with sharp-edge tools or the sharp surfaces of the vehicle underbody.

3. Pull the park brake cable equalizer toward the rear of the vehicle and place a locking plier with protected jaws on the cable to hold the cable in an extended position.
4. Lower the vehicle.

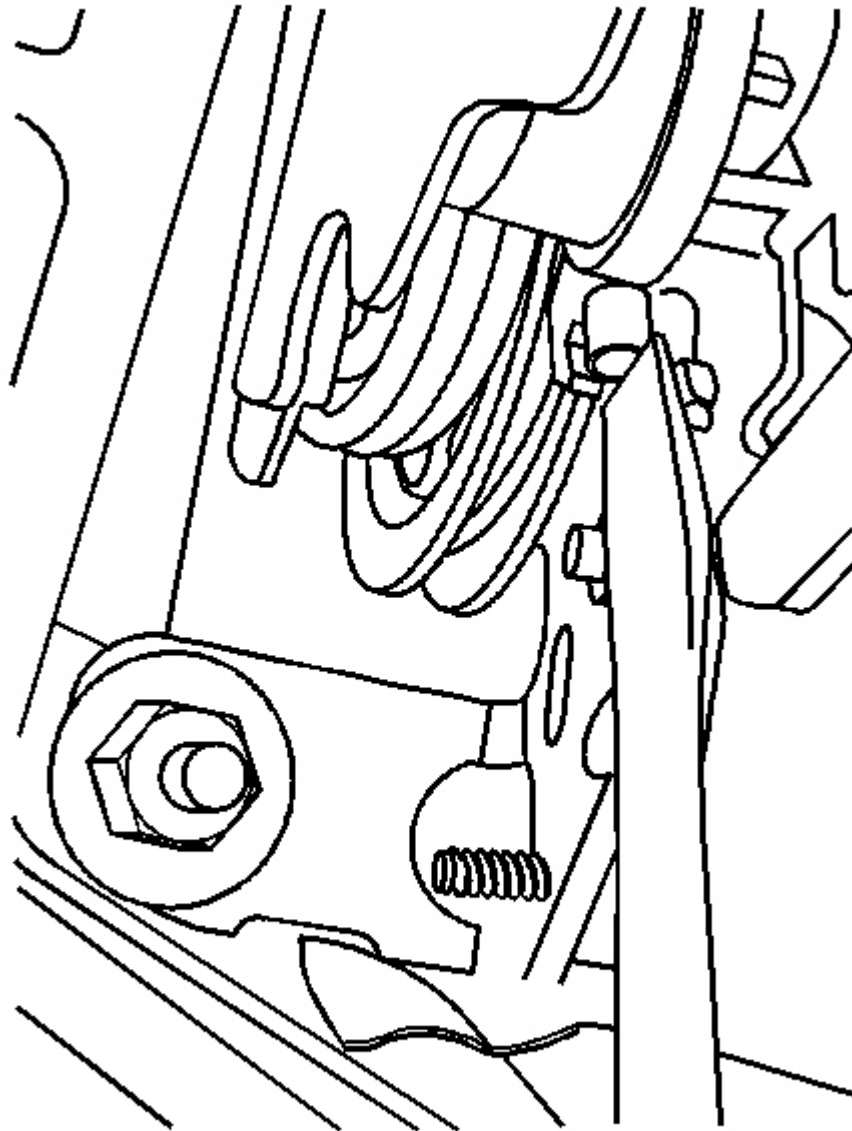

Fig. 45: Park Brake Cable Automatic Adjuster View
Courtesy of GENERAL MOTORS CORP.

5. Rotate the self-adjust clip into the lock position with a flat-bladed tool.
6. Raise the vehicle.
7. Remove the locking plier from the park brake cable.

2004 Isuzu Ascender LS

2004 BRAKES Park Brake - Ascender

8. Lower the vehicle.
9. Partially raise the park brake lever, stopping prior to the self-adjust clip (1) activating on the mount bracket tab.
10. Insert a flat bladed tool behind the self-adjust clip and twist the tool 90 degrees to raise the self-adjust clip over the mount bracket tab.
11. Raise the handle until it is fully applied and remove the screwdriver.

ENABLING THE PARK BRAKE CABLE AUTOMATIC ADJUSTER

1. Lower the park brake lever.
2. Raise the park brake lever.
3. Lift the park brake lever boot to gain access to the multiplier lever at the front of the park brake lever assembly.
4. Pivot the multiplier lever up and down 3 times.
5. Cycle the park brake lever up and down three times for auto adjustment.
6. Lower the park brake lever boot.

PARK BRAKE ACTUATOR REPLACEMENT

CAUTION: Refer to Brake Dust Caution in Cautions and Notices.

Removal Procedure

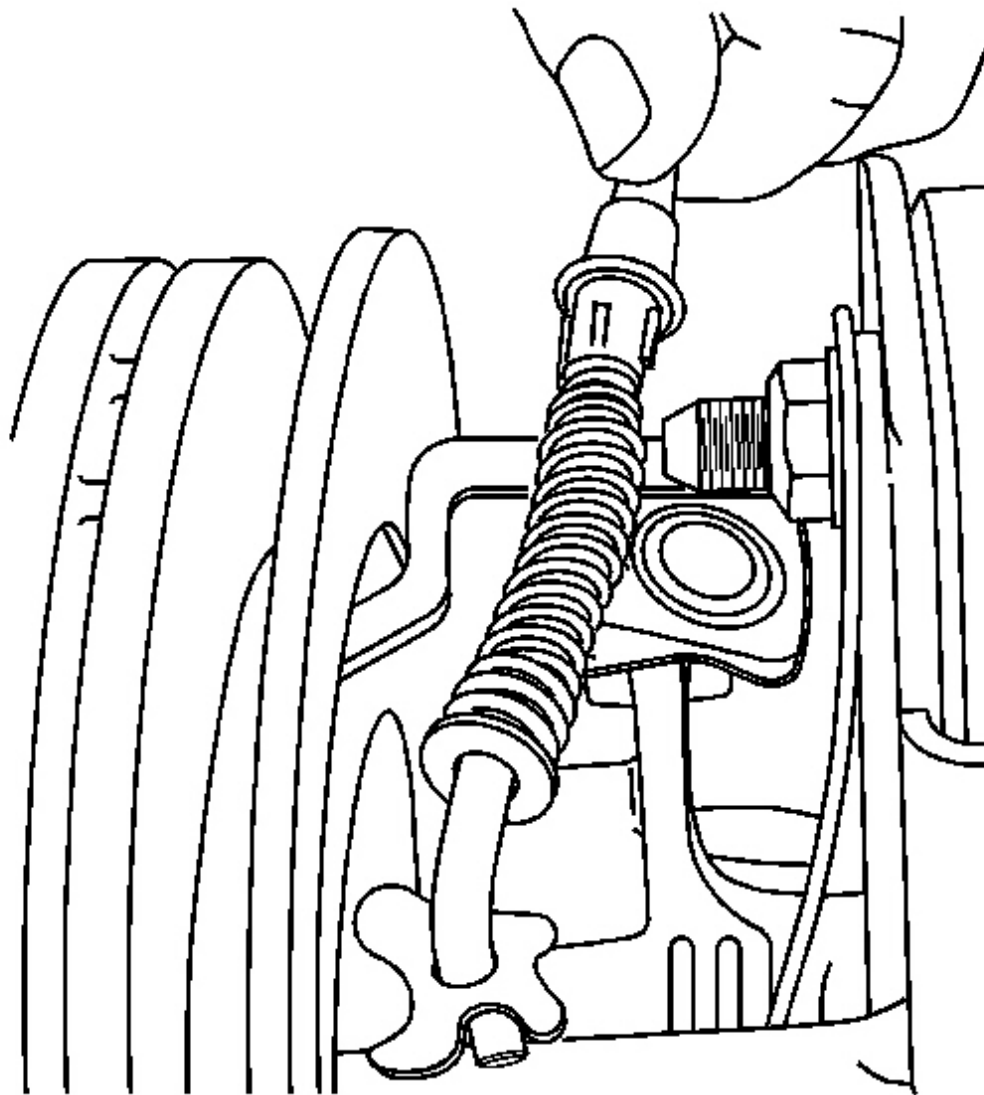

Fig. 46: View Of Parking Brake Cable
Courtesy of GENERAL MOTORS CORP.

1. Disable the park brake automatic adjuster. Refer to **Disabling the Park Brake Cable Automatic Adjuster**.
2. Raise the vehicle. Refer to **Lifting and Jacking the Vehicle** in General Information.
3. Remove the tire and wheel assembly. Refer to **Tire and Wheel Removal and Installation** in Tires and Wheels.

4. Remove the park brake cable from the mounting bracket by depressing the locking tabs.
5. Remove the rear park brake cable from the park brake actuator lever.

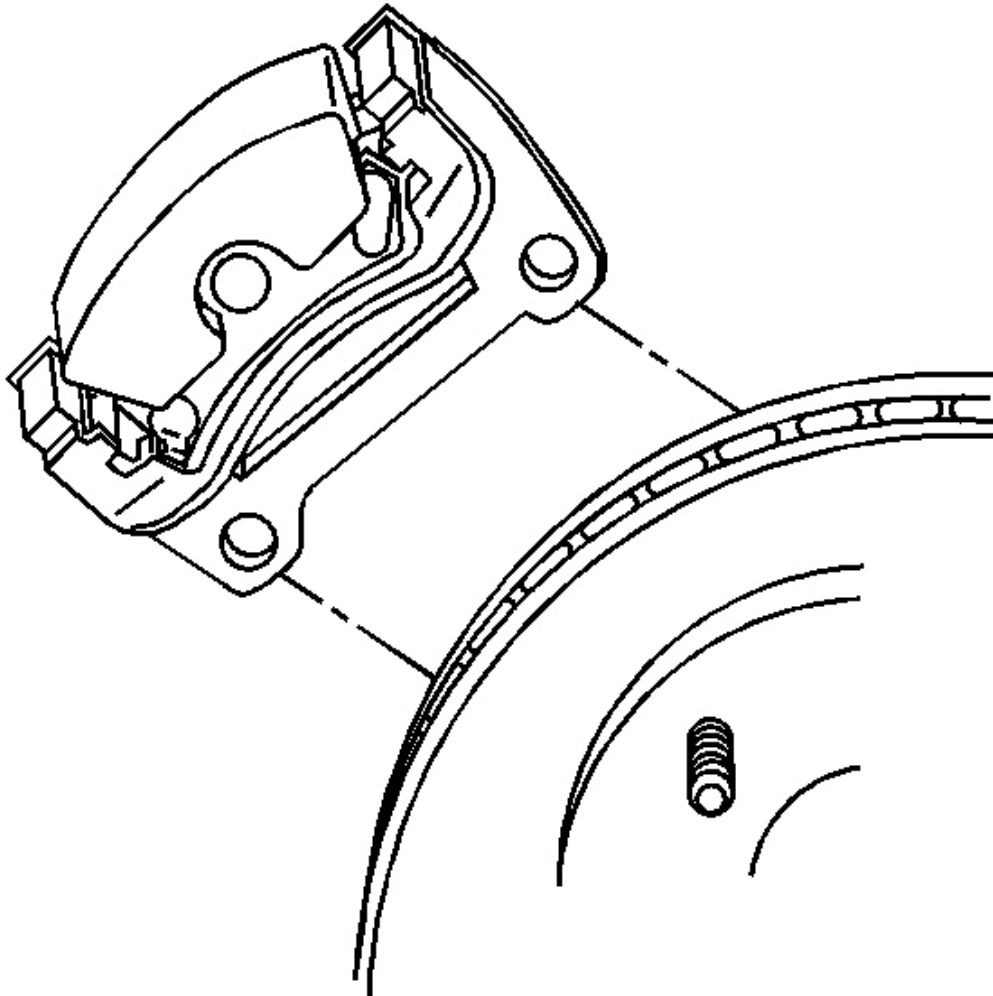

Fig. 47: View Of Caliper Bracket
Courtesy of GENERAL MOTORS CORP.

6. Remove the rear brake caliper and mounting bracket assembly. Refer to **Brake Caliper Bracket Replacement - Rear** in Disc Brakes.

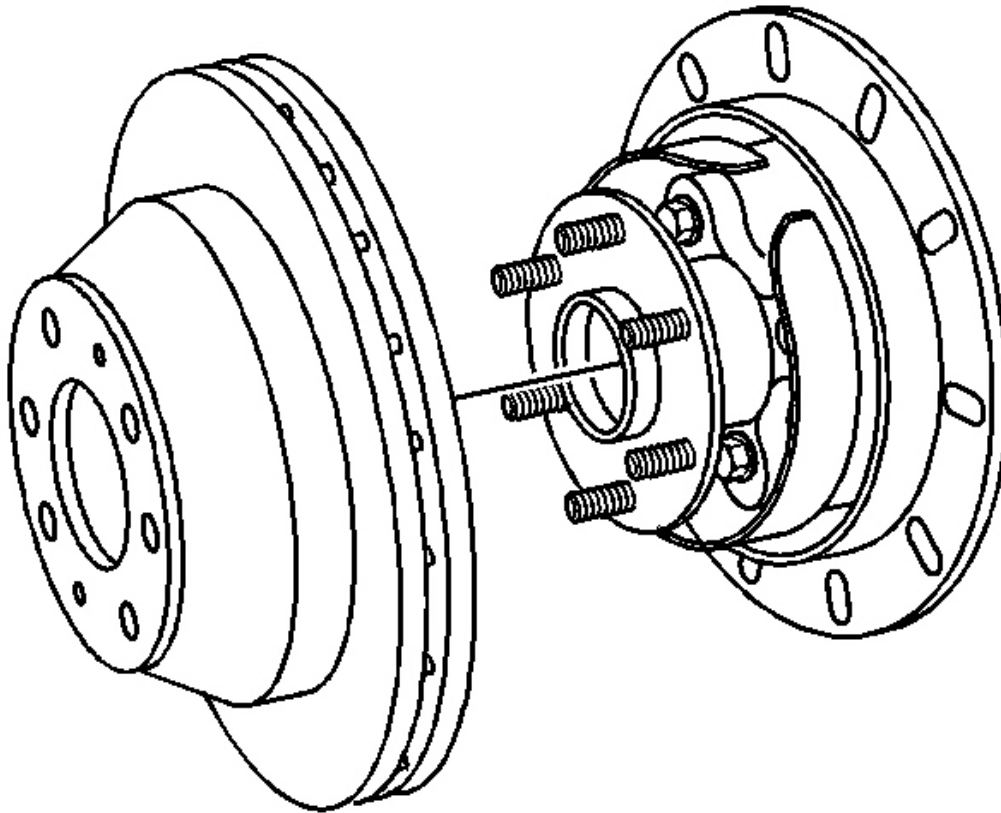

Fig. 48: View Of Rotor To Hub
Courtesy of GENERAL MOTORS CORP.

7. Remove the rear brake rotor.

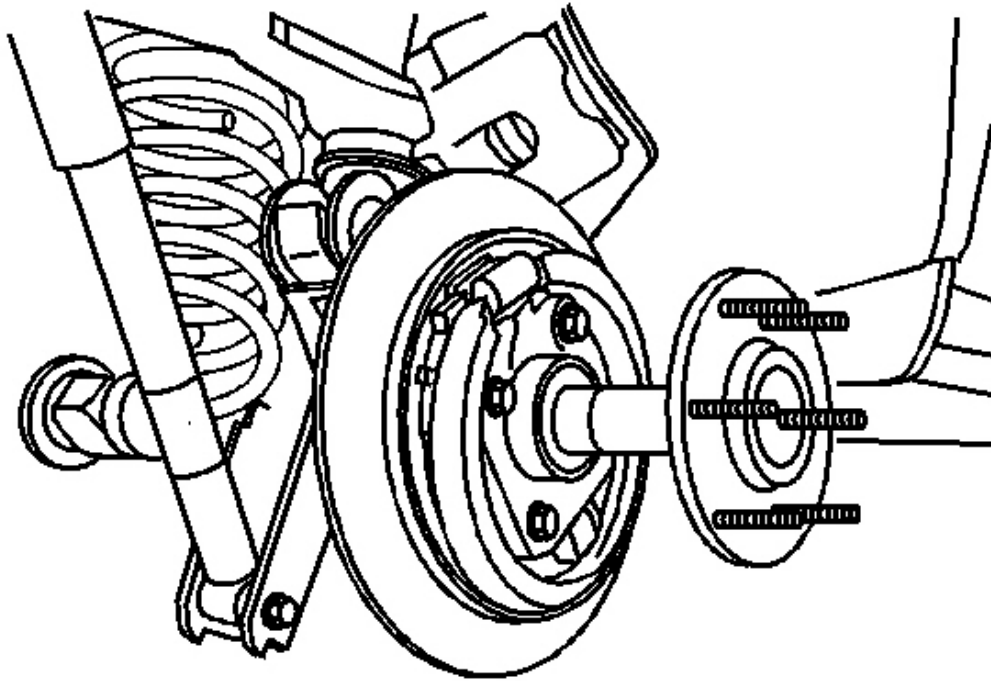

Fig. 49: View Of Rear Axle Assembly
Courtesy of GENERAL MOTORS CORP.

8. Remove the axle shaft. Refer to **Rear Axle Shaft Replacement** in Rear Drive Axle.

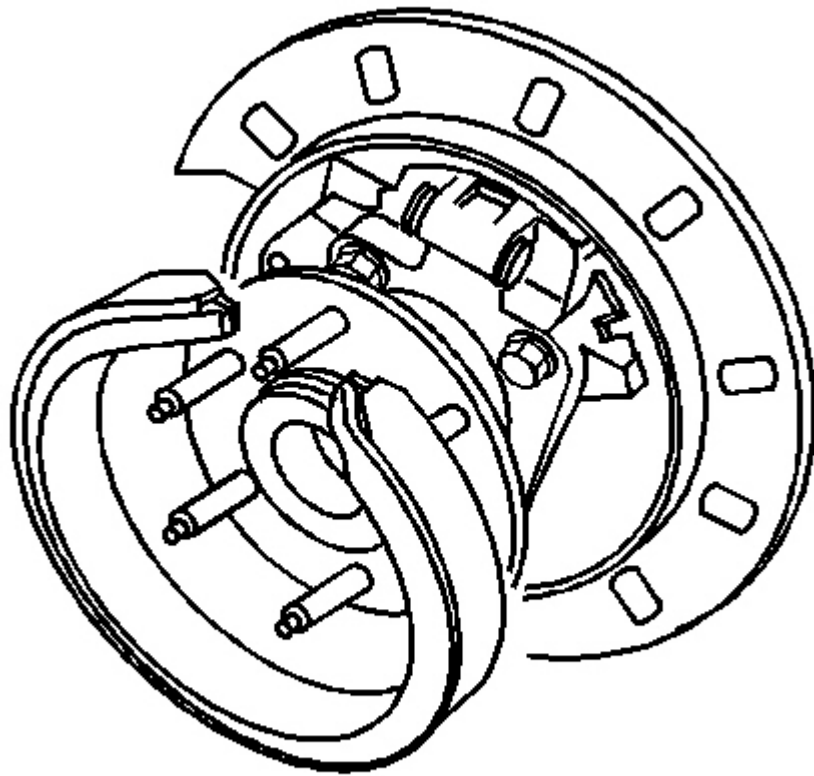

Fig. 50: View Of Park Brake Shoe
Courtesy of GENERAL MOTORS CORP.

9. Remove the park brake shoe. Refer to **Park Brake Shoe Replacement**.

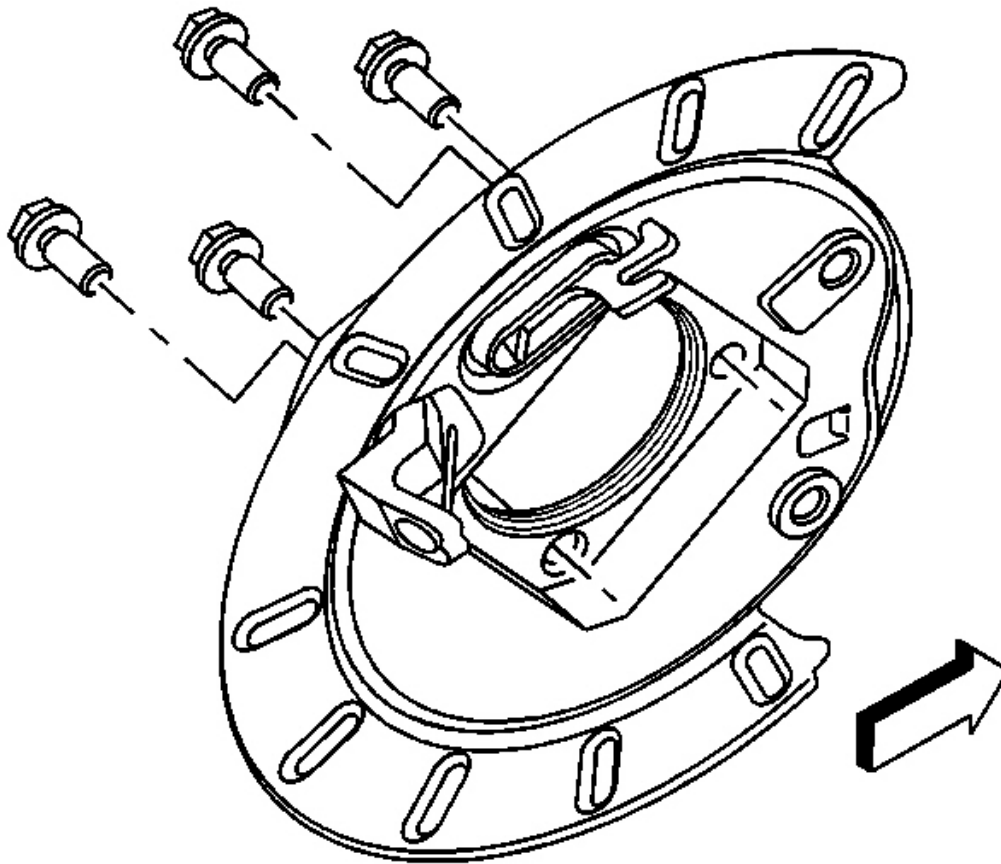

Fig. 51: Identifying Backing Plate Bolts
Courtesy of GENERAL MOTORS CORP.

10. Remove the backing plate bolts.
11. Remove the park brake actuator lever housing from the backing plate.
12. Using denatured alcohol, clean the backing plate and parking brake actuator.
13. Using non-lubricated, filtered air, dry the backing plate.

Installation Procedure

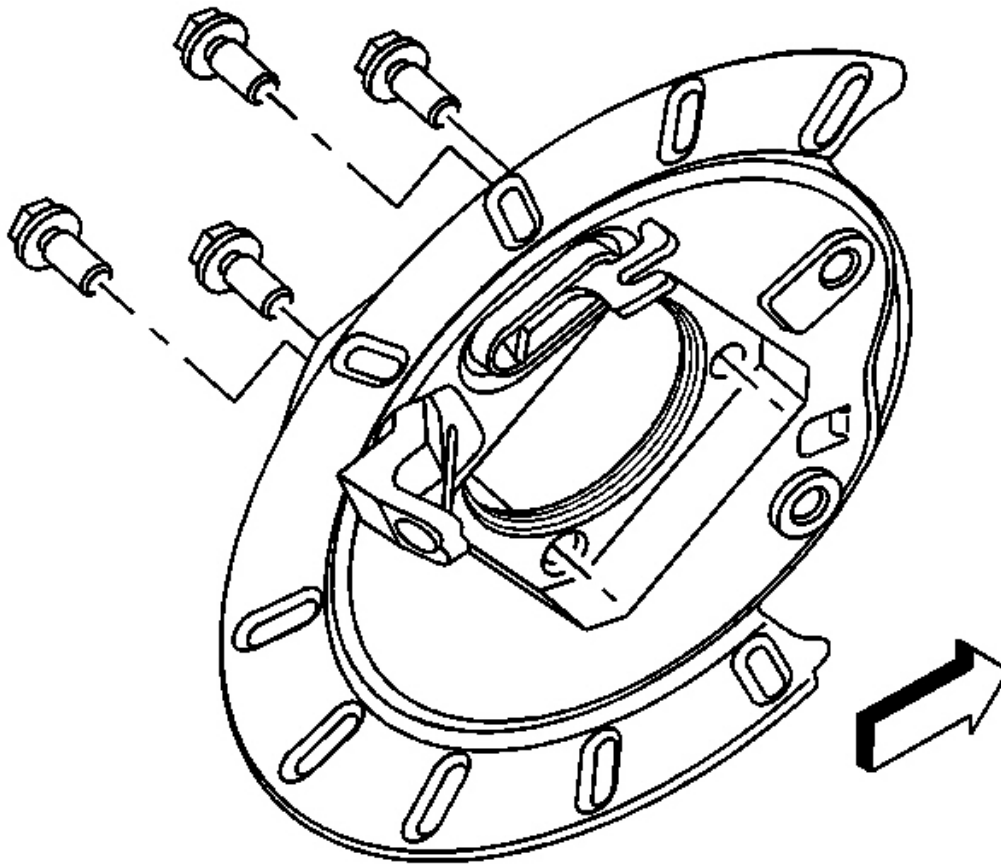

Fig. 52: Identifying Backing Plate Bolts
Courtesy of GENERAL MOTORS CORP.

1. Install the park brake actuator lever housing to the backing plate.
2. Perform the following procedure before installing the backing plate bolts.
 1. Remove all traces of the original adhesive patch.
 2. Clean the threads of the bolt with brake parts cleaner or the equivalent and allow to dry.
 3. Apply Threadlocker GM P/N 12345493 (Canadian P/N 10953488) to the threads of the bolt.

NOTE: Refer to Fastener Notice in Cautions and Notices.

3. Install the backing plate bolts.

Tighten: Tighten the backing plate bolts to 135 N.m (100 lb ft).

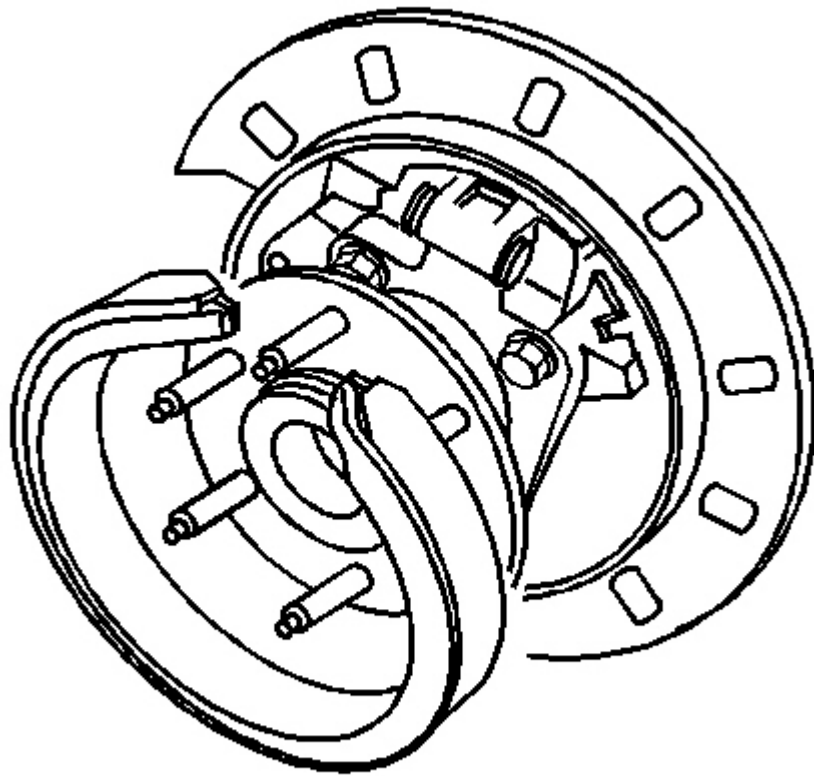

Fig. 53: View Of Park Brake Shoe
Courtesy of GENERAL MOTORS CORP.

4. Install the park brake shoe. Refer to **Park Brake Shoe Replacement**.

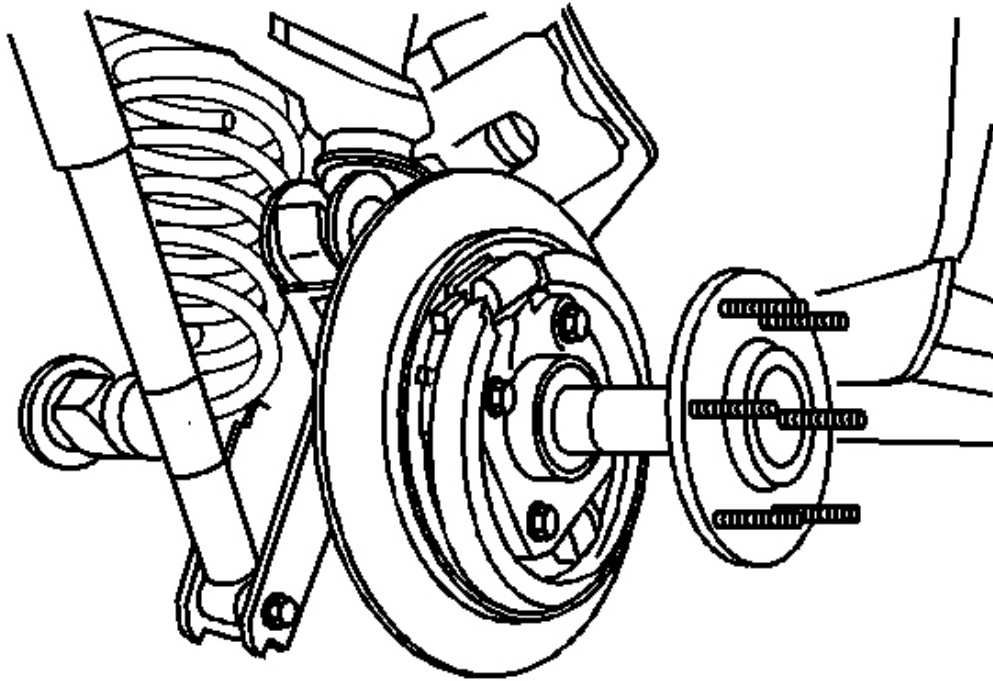

Fig. 54: View Of Rear Axle Assembly
Courtesy of GENERAL MOTORS CORP.

5. Install the axle shaft. Refer to **Rear Axle Shaft Replacement** in Rear Drive Axle.

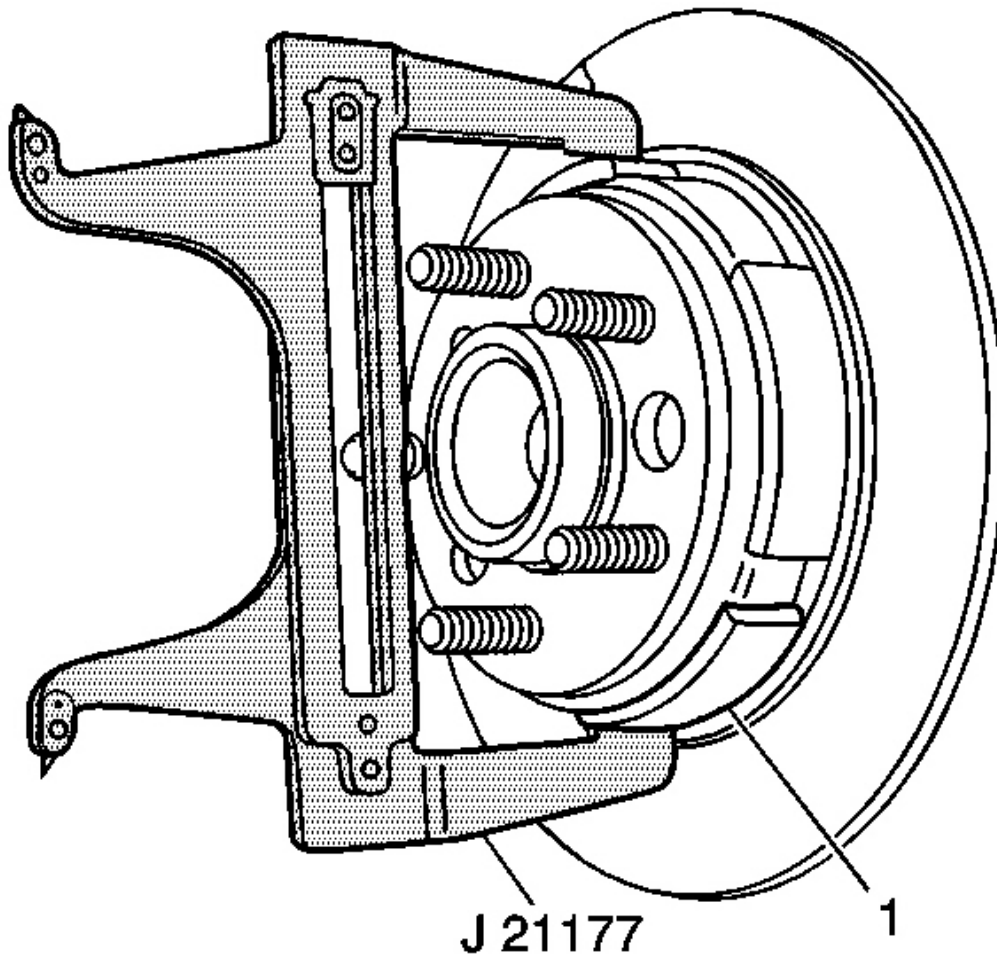

Fig. 55: Adjusting Parking Brake Shoes Using Special Tool
Courtesy of GENERAL MOTORS CORP.

6. Adjust the park brake shoe (1). Refer to **Park Brake Adjustment**.

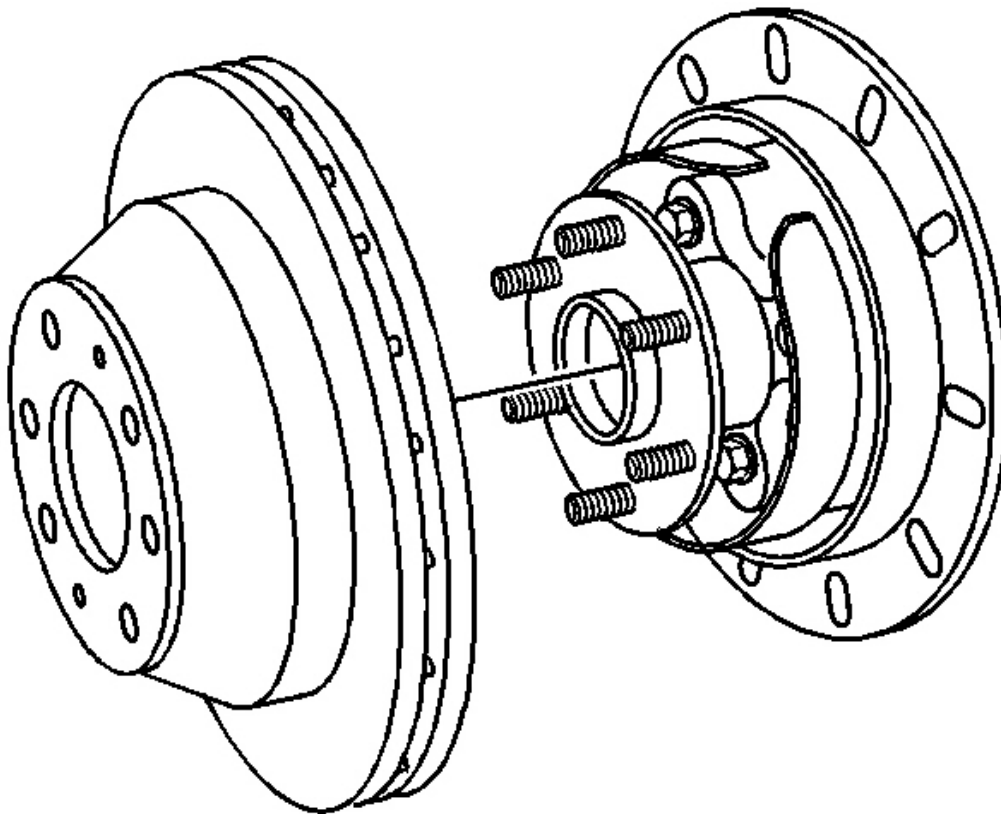

Fig. 56: View Of Rotor To Hub
Courtesy of GENERAL MOTORS CORP.

7. Install the rear brake rotor.

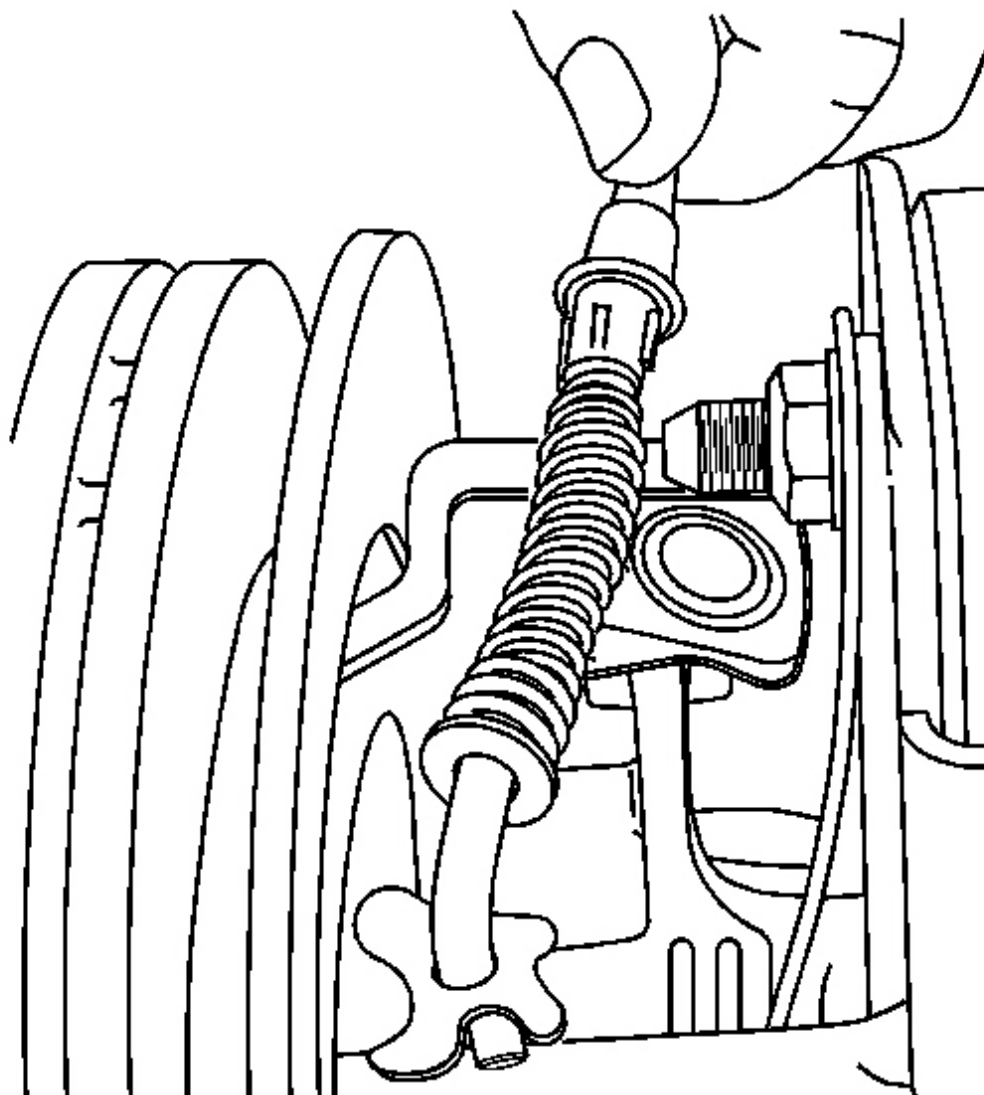

Fig. 57: View Of Parking Brake Cable
Courtesy of GENERAL MOTORS CORP.

8. Install the rear park brake cable to the park brake actuator lever.

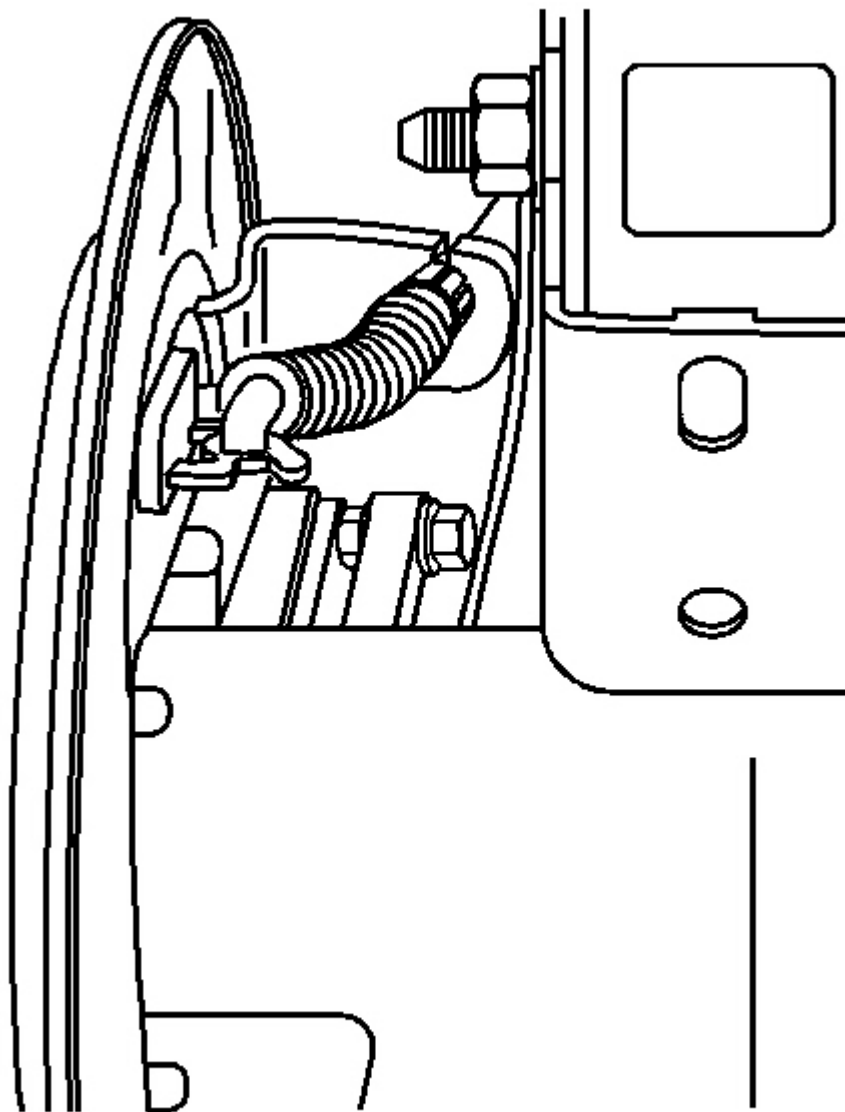

Fig. 58: Park Brake Retainer View
Courtesy of GENERAL MOTORS CORP.

9. Install the park brake cable to the mounting bracket, ensuring the locking tabs are secured.

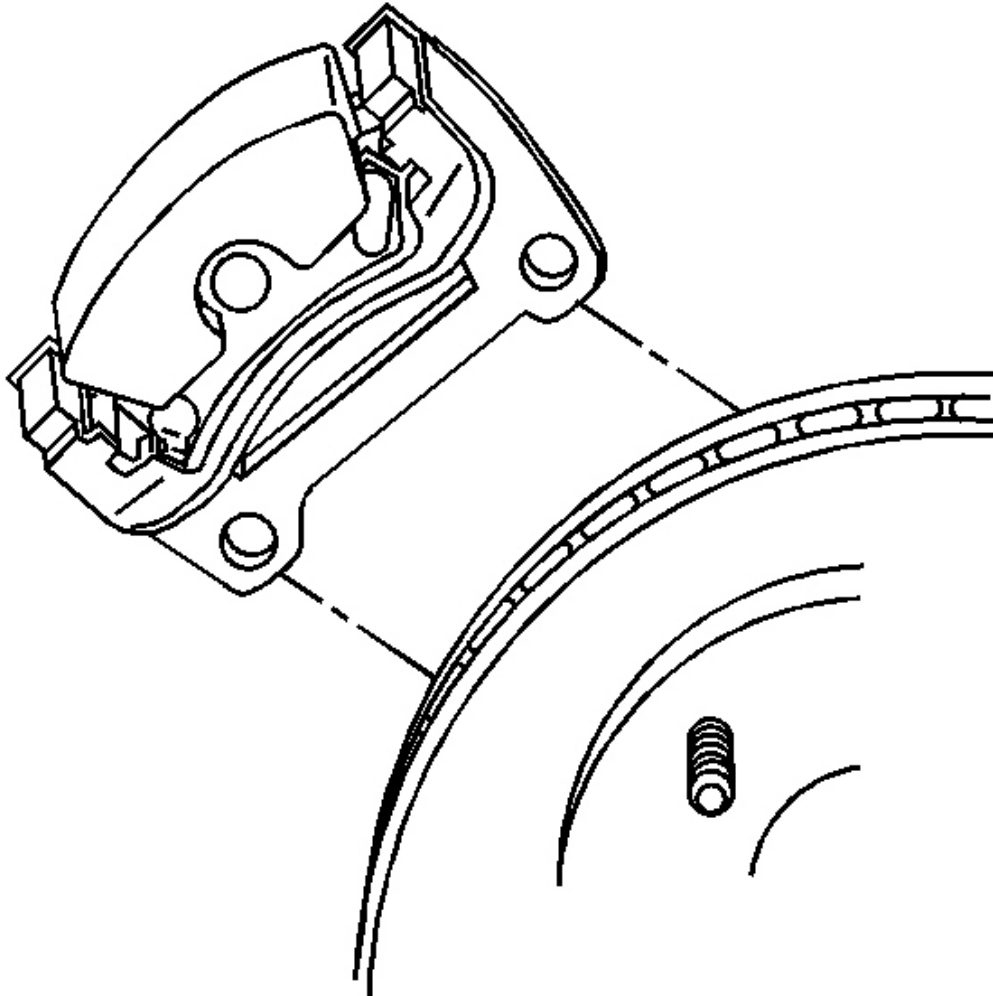

Fig. 59: View Of Caliper Bracket
Courtesy of GENERAL MOTORS CORP.

10. Install the rear brake caliper and mounting bracket assembly. Refer to **Brake Caliper Bracket Replacement - Rear** in Disc Brakes.
11. Install the tire and wheel assembly. Refer to **Tire and Wheel Removal and Installation** in Tires and Wheels.
12. Lower the vehicle. Refer to **Lifting and Jacking the Vehicle** in General Information.
13. Enable the park brake automatic adjuster. Refer to **Enabling the Park Brake Cable Automatic Adjuster**.

PARK BRAKE ADJUSTMENT

Tools Required

J 21177-A Drum-to-Brake Shoe Clearance Gage

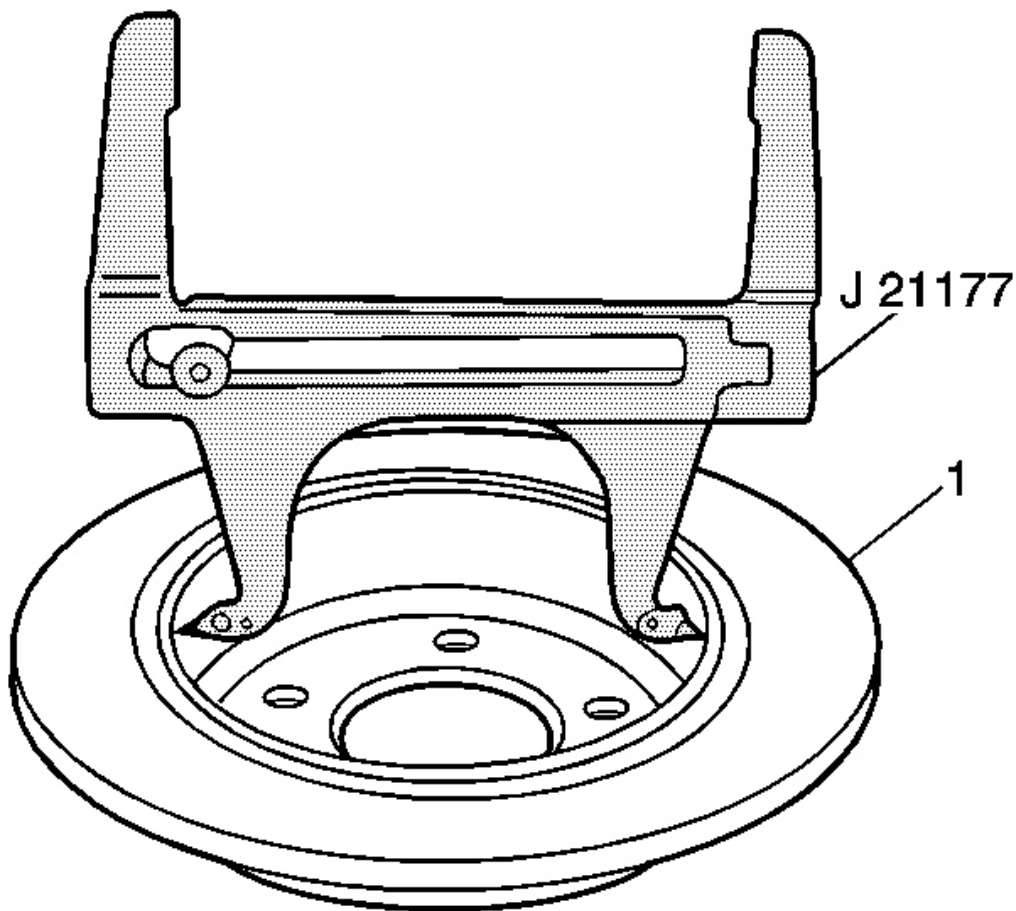

Fig. 60: Measuring Inside Of Rotor
Courtesy of GENERAL MOTORS CORP.

1. Adjust the J 21177-A until it contacts the inside diameter of the rotor (1).

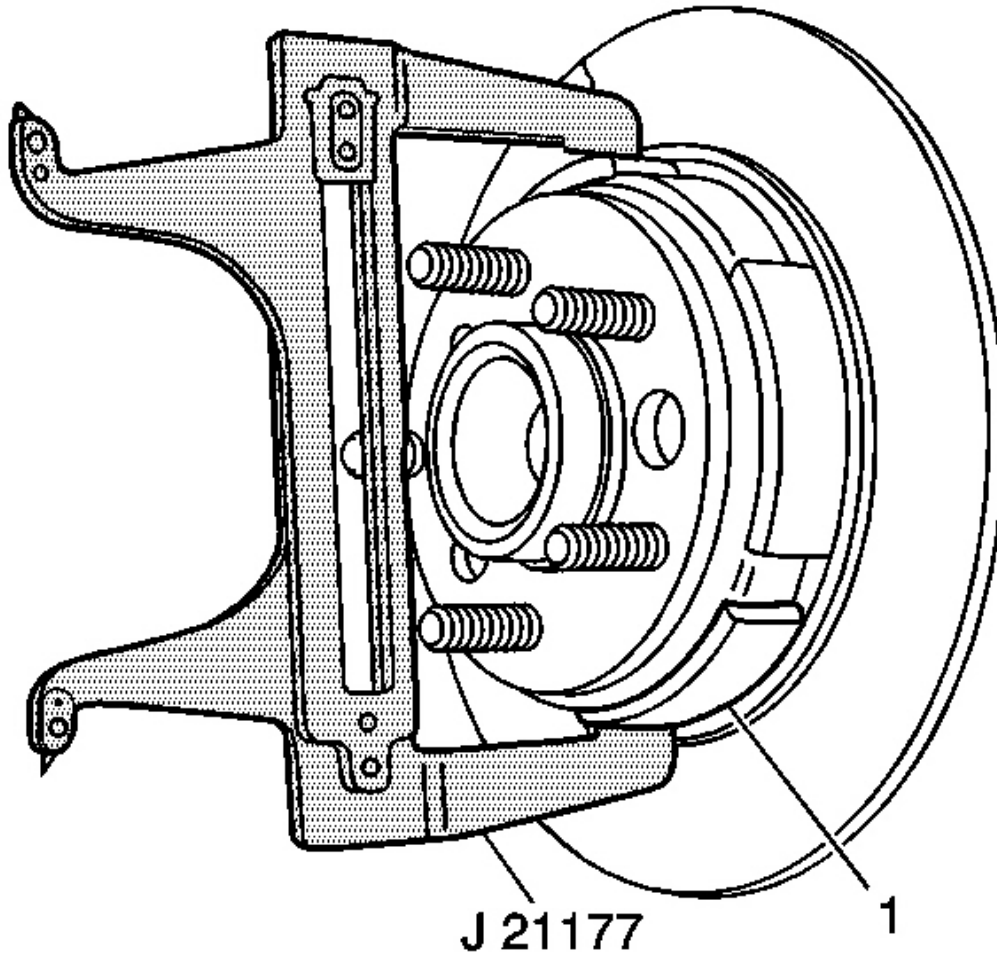

Fig. 61: Adjusting Parking Brake Shoes Using Special Tool
Courtesy of GENERAL MOTORS CORP.

2. Position the **J 21177-A** over the park shoe lining, left side shown, at the widest point (1).
3. Turn the adjuster nut until the lining just contacts the **J 21177-A**.
4. Repeat steps 1 through 3 to adjust the right rear park brake.
5. The clearance between the rear park brake shoe lining and the rotor should be 0.25 mm (0.010 in) or 0.50 mm (.020 in) total.

DESCRIPTION AND OPERATION

PARK BRAKE SYSTEM DESCRIPTION AND OPERATION

2004 Isuzu Ascender LS

2004 BRAKES Park Brake - Ascender

System Component Description

The park brake system consists of the following:

Park Brake Lever Assembly

Receives and transfers park brake system apply input force from driver to park brake cable system. Releases applied park brake system when lever is returned to at-rest (lowered) position.

Park Brake Cables

Transfers input force received from park brake lever, through park brake cable equalizer, to park brake apply lever.

Park Brake Cable Equalizer

Evenly distributes input force to both the left and right park brake units. Threaded park brake cable equalizers are also used to remove slack in park brake cables.

Park Brake Apply Lever

Multiplies and transfers input force to park brake actuator.

Park Brake Actuator

Uses multiplied input force from apply lever to expand park brake shoe toward the friction surface of the drum-in-hat portion of the rear brake rotor. Threaded park brake actuators are also used to control clearance between the park brake shoe and the friction surface of the drum-in-hat portion of the rear brake rotor.

Park Brake Shoe

Applies mechanical output force from park brake actuator to friction surface of the drum-in-hat portion of the rear brake rotor.

System Operation

Park brake apply input force is received by the park brake lever assembly being depressed, transferred and evenly distributed, through the park brake cables and the park brake cable equalizer, to the left and right park brake apply levers. The park brake apply levers multiply and transfer the apply input force to the park brake actuators which expand the park brake shoe toward the friction surface of the drum-in-hat portion of the rear brake rotor in order to prevent the rotation of the rear tire and wheel assemblies. The park brake lever assembly releases an applied park brake system when it is returned to the at-rest (lowered) position.

SPECIAL TOOLS AND EQUIPMENT

SPECIAL TOOLS

2004 Isuzu Ascender LS

2004 BRAKES Park Brake - Ascender

Special Tools

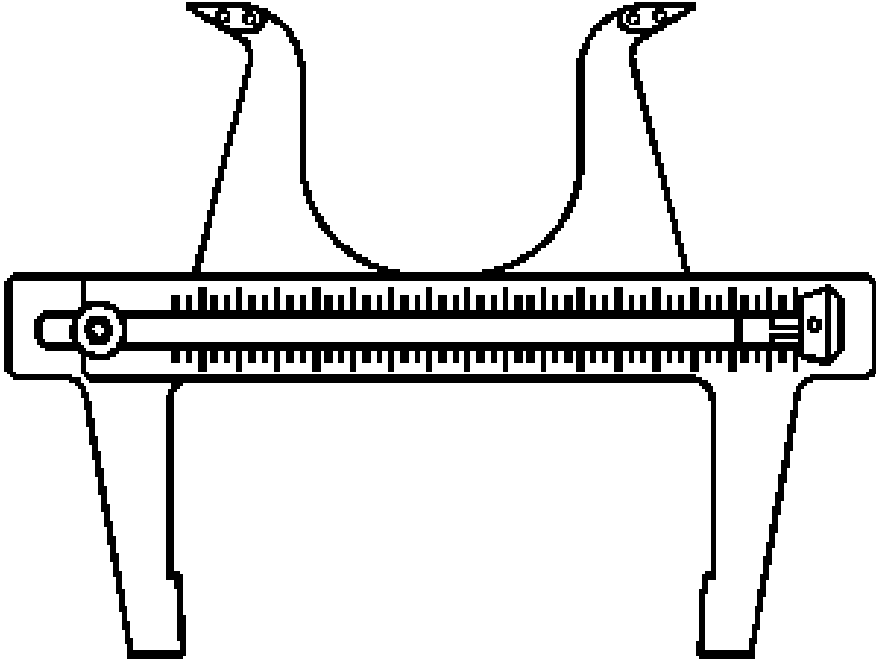
Illustration	Tool Number/ Description
	<p>J 21177 - A Drum-to-Brake Shoe Clearance Gage</p>

2004 Isuzu Ascender LS

2004 BRAKES Park Brake - Ascender

Park Brake Cable
Release Tool

